

MAPAL'S PVC 110 GUTTER SYSTEM FOR STRAWNERRIES



INDEX

1. INTRODUCTION.....	1
2. DIMENSIONS.....	2
3. CONNECTIONS.....	3-5
4. SPACING OF THE PVC 110 GUTTERS.....	6
5. SUSPENSION METHODS.....	7-10
6. POLYPROPYLEN GROWING CONTAINERS.....	11
7. DRAINAGE COLLECTION SYSTEM.....	14
8. FULL GROWING SYSTEM.....	15-16
9. STORING AND UNLOADING THE PVC 110 GUTTERS.....	17-18
10. IMPORTANT THINGS TO REMEMBER.....	19
11. RECOMENDATIONS.....	20
12. GLUE MANUFACTURERS, PVC ADHESIVE & ADHESIVE SAFETY DATA SHEET.....	21-27

INTRODUCTION

MAPALS' PVC 110 GUTTER SYSTEM

The strawberry growing Industry has undergone many changes and many new systems have been introduced to the market but the Mapal PVC 110 Gutter system, an innovative product of Mapals' Agricultural Division, has proven to be a high quality, successful and economically worthwhile system.

The PVC 110 Gutter system, which has been in use for many years in countries around the world, allows to successfully grow a higher number of plants per square meter (up to 20 plants per square meter) enabling the grower to maximize the use of the greenhouse space thus getting a higher return on their investment.

Mapal's PVC 110 Gutter is durable, strong and offered in different lengths, to best cater to the growers demands.

The system is versatile enough to allow for either a standing or a hanging set up in the greenhouse.

Mapal's PVC gutter is mainly used with the Mapal polypropylene containers although it can be used with any grow bag (perlite, coco peat, rock wool, Peat) or any other kind of substrate.

Mapal's PVC gutter system allows for the most efficient recycling of the irrigation water, reduce evaporation and weed growth and because it can be suspended or elevated, it reduces any rotting or spoiling of the fruit due to contact with the soil.

Picking fruit with Mapal's PVC gutter system is easier and faster because of the height the gutters are set at and the easy access to the fruit, which naturally droops while the leaves tend to rise towards the light.

Mapal offers a full system, which includes the PVC gutters, growing containers and drainage collection.

PROFILE DIMENSIONS FOR THE PVC 110 DRAINAGE GUTTER

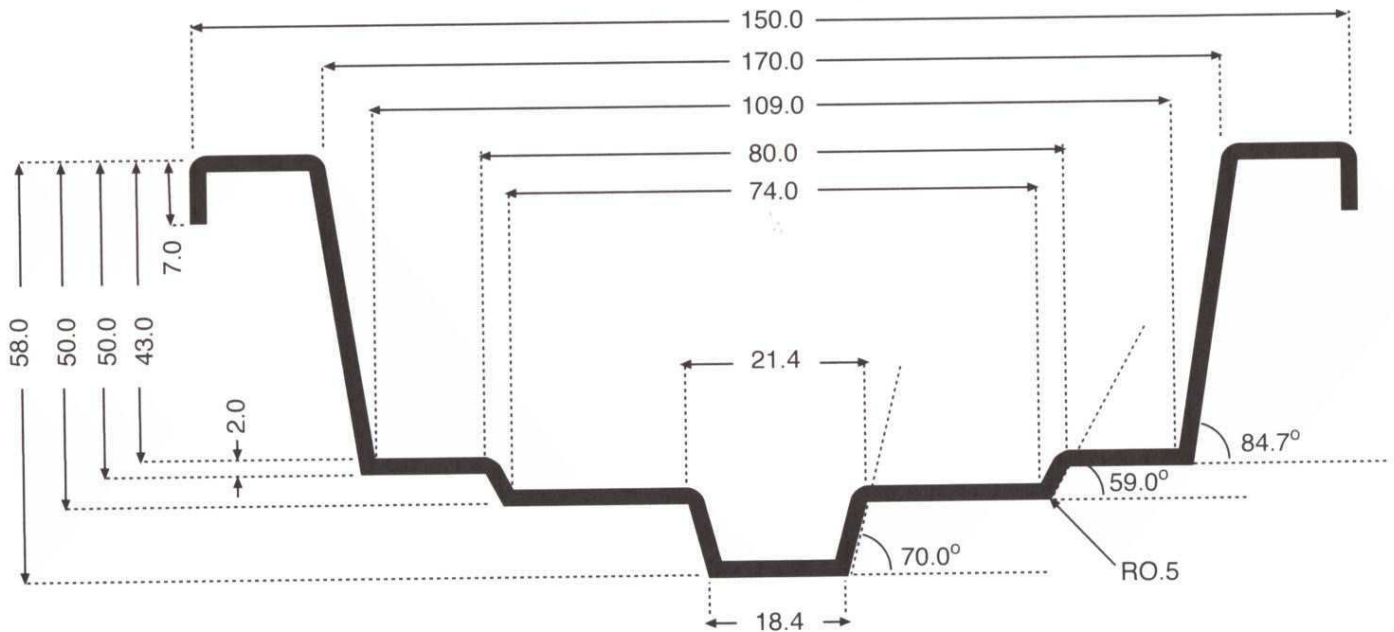

The PVC 110 Gutter is offered in two main lengths:

5.85 Meters-which fits a 20 foot container

11.70 Meters-which fits a 40 foot container

The PVC 110 Gutter can be supplied in any length.

The recommended length for the PVC 110 Gutter is for up to 35 Meters. When the row is longer, we suggest cutting the gutter into sections to allow for better drainage collection conditions.

CONNECTIONS

MAPAL'S PVC Gutter indentations, which are an added feature enabling an easy and clean fit.

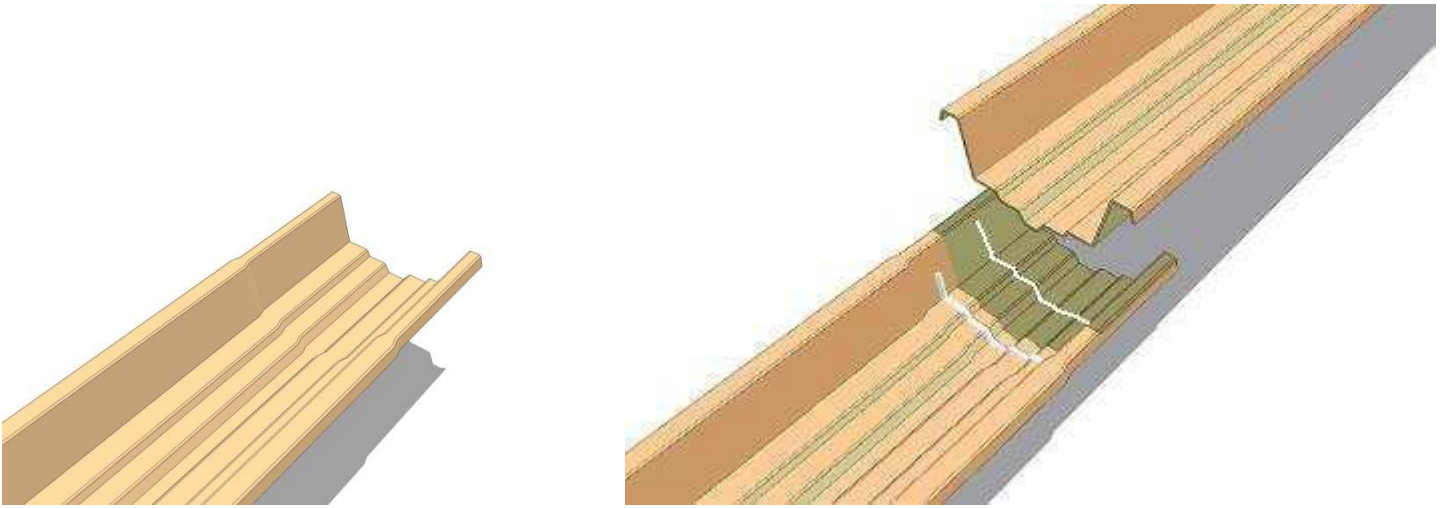

The indentation allows for a tight fit.

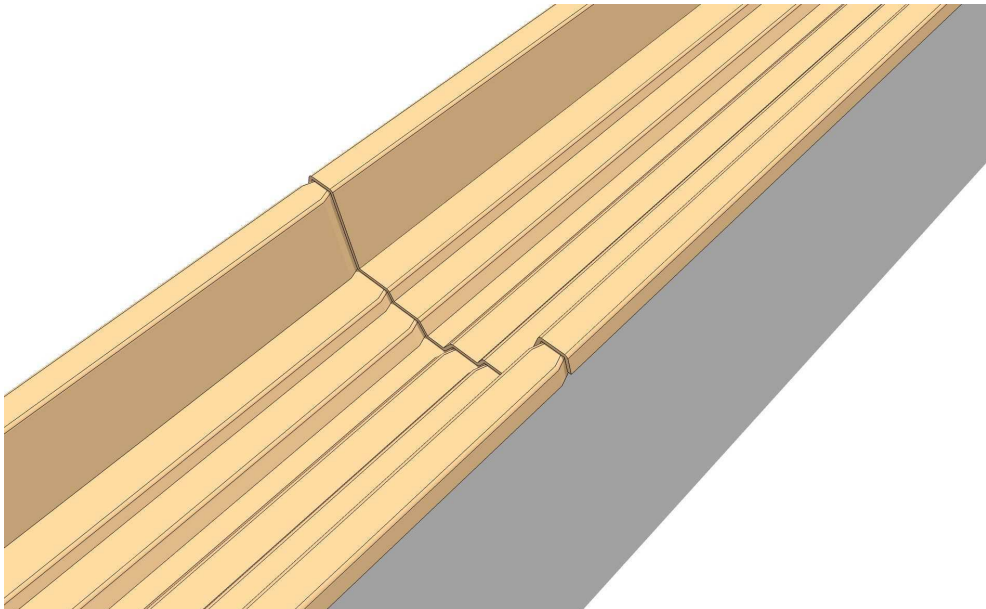

ADHESIVE APPLICATION INFORMATION

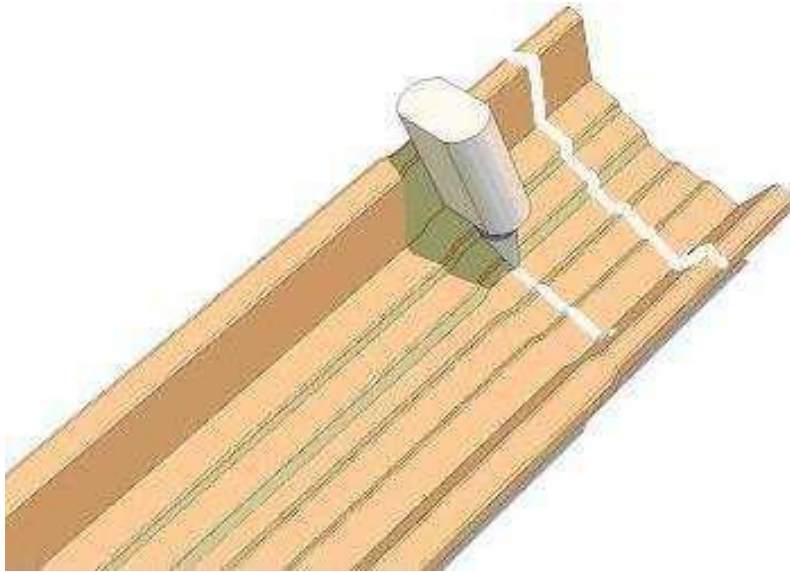

1. Surfaces must be dry, clean and dust free.
2. Apply two uniform layers of adhesive on one side and glue together within a short period of time. Add another line of adhesive on the inside connection to ensure there is no leakage (see drawing below).

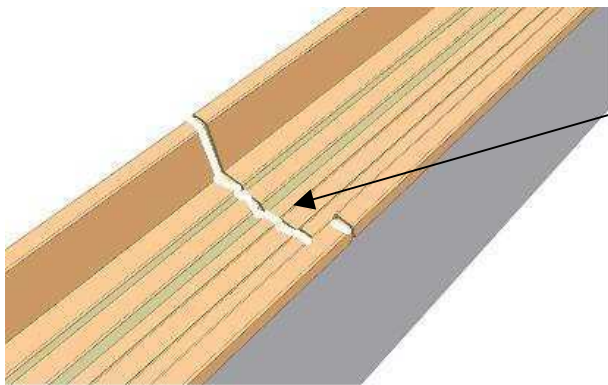

The additional line of PVC adhesive will ensure that there is no leakage

3. Apply constant pressure while drying.

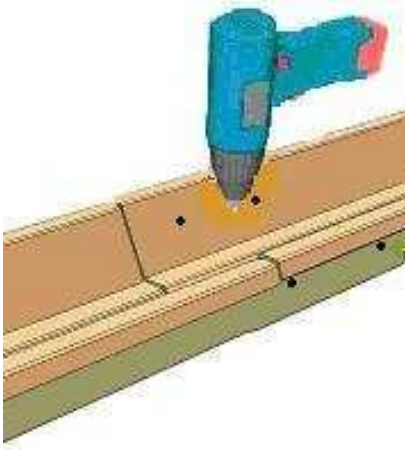

This can be achieved by drilling in screws or inserting rivets (from the inside out) in the designated areas while the glue is still setting

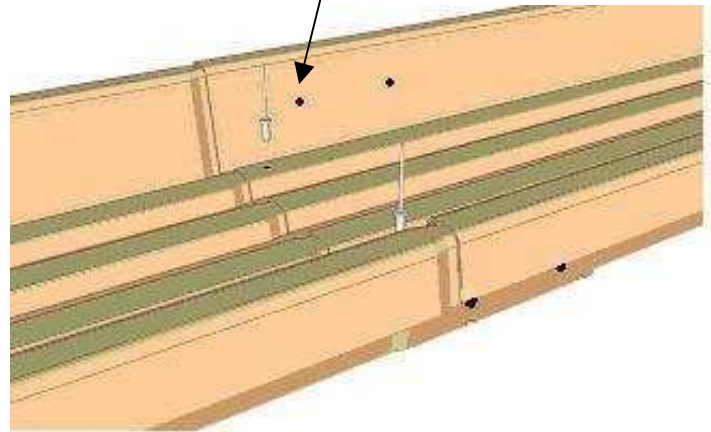

The gutters must be assembled, Glued and rivets or screws drilled In while the PVC gutters lie on a straight level surface.

Do not attempt to apply pressure with other objects.

4. **Let dry for 24 hours**, before moving or hanging.
5. After drying, the adhesive layer continues to strengthen.
6. Clean hands with Acetone.

Precautions:

7. Refer to Material Safety Data Sheet before using this product.

All references and information regarding the recommended glue see page 21-27

Spacing of PVC 110 Gutters

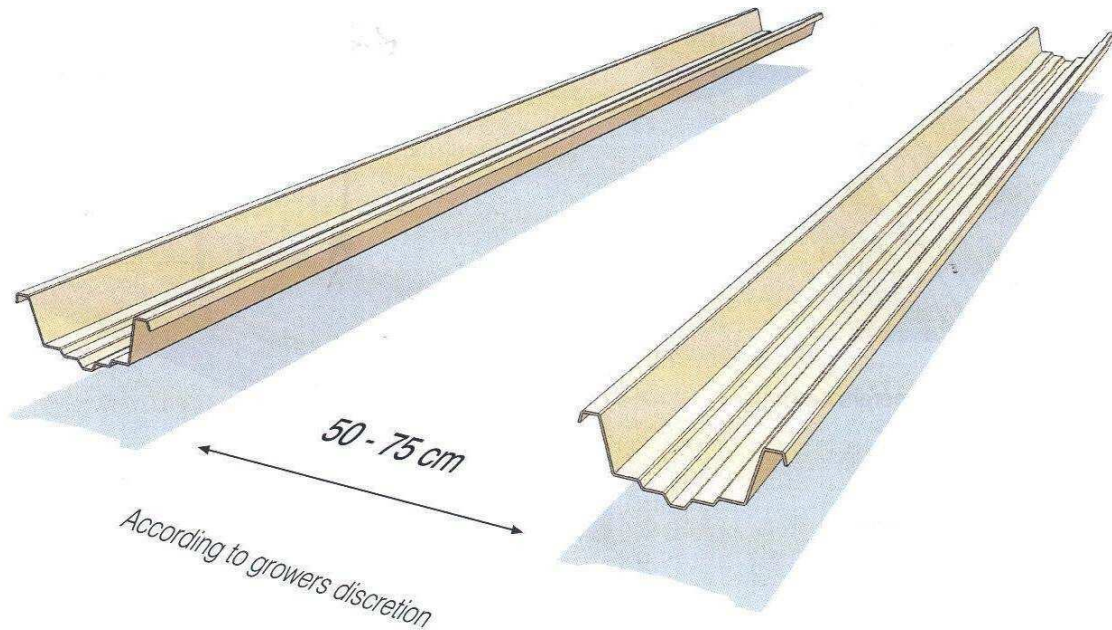

The most common spacing of the troughs is of 50 to 75cm. The recommended spacing of the troughs is given here to help the grower maximize the amount of light the crops receive.

Because countries are at different light angles, it is important to adjust the spacing accordingly.

Suspension methods

Suspend the gutter by vertical cables first, at a 1 to 1.5% slope.
Then suspend by the diagonal cables and align the gutter by shortening or extending the cables

Greenhouse gutter line

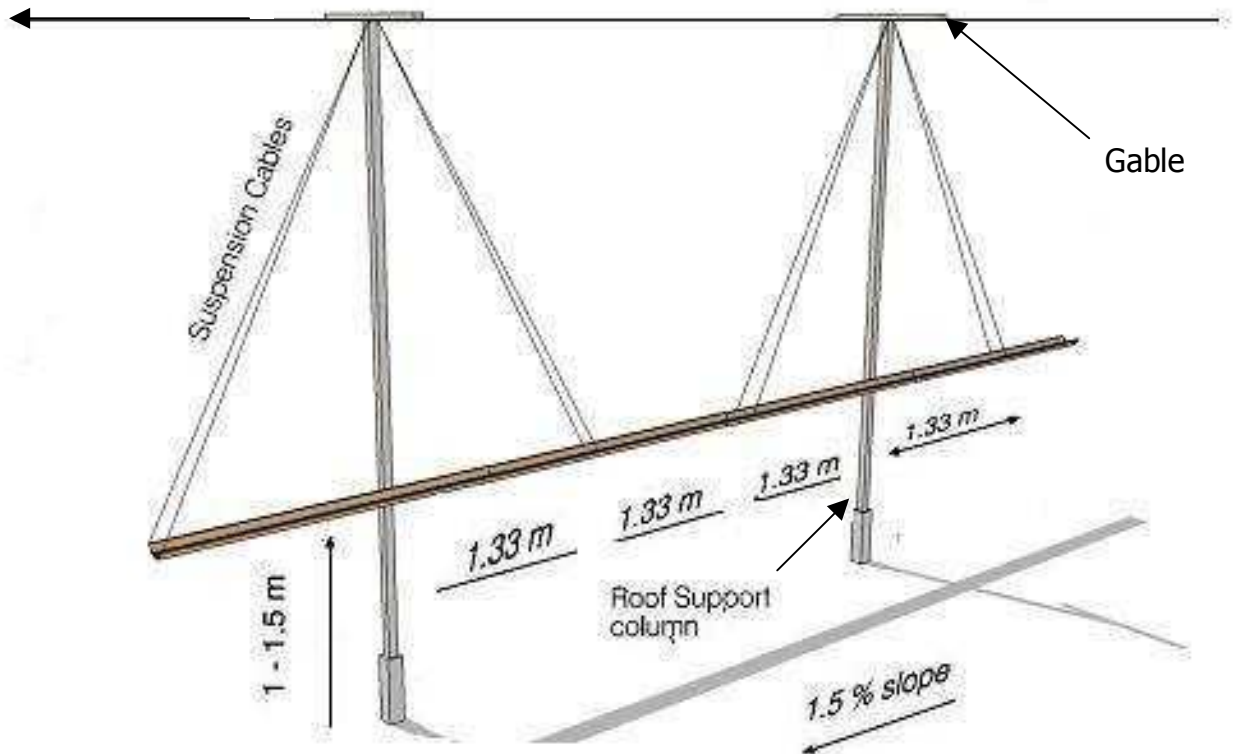

SUSPENDING PVC GUTTERS IN GREENHOUSE



Preparing PVC 110 for hanging with Metal Wire

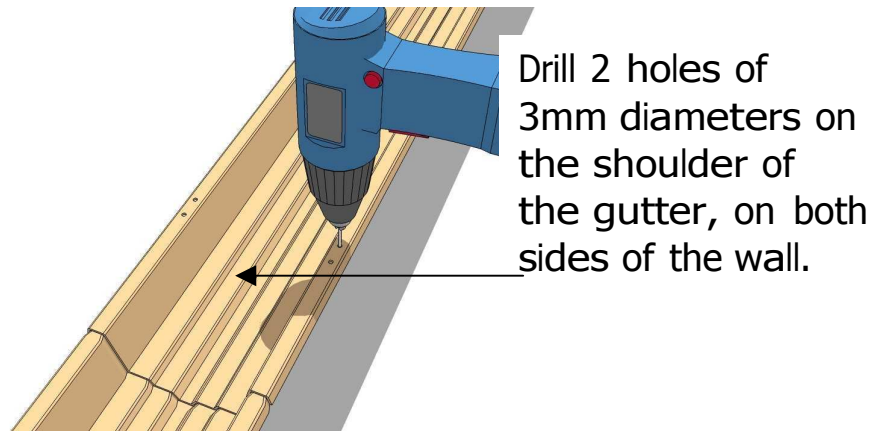

Thread the suspension wires or cable through the shoulder holes, leave free wire length of 10-15cm for balancing the gutter slope later.

Place wires or cables every 1.33 meters on the PVC Gutter.

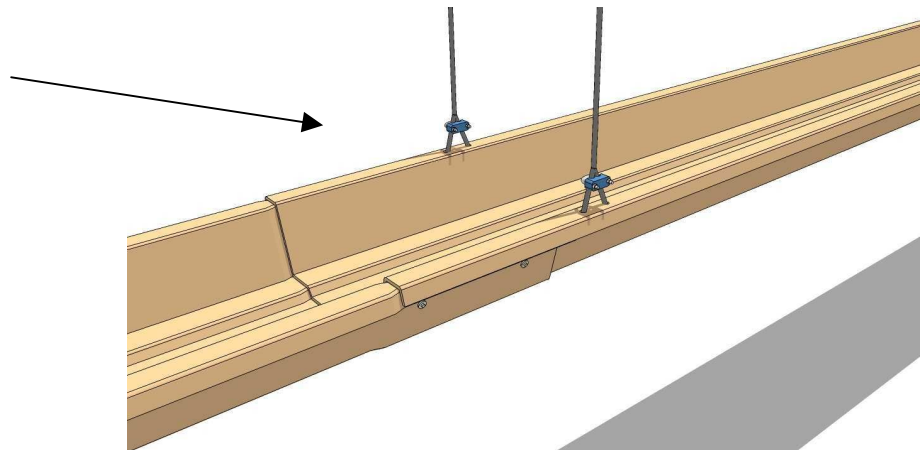

Threaded suspension wire with a twist



Preparing PVC 110 for hanging with Metal Chain

Use nut and bolt to connect the chain

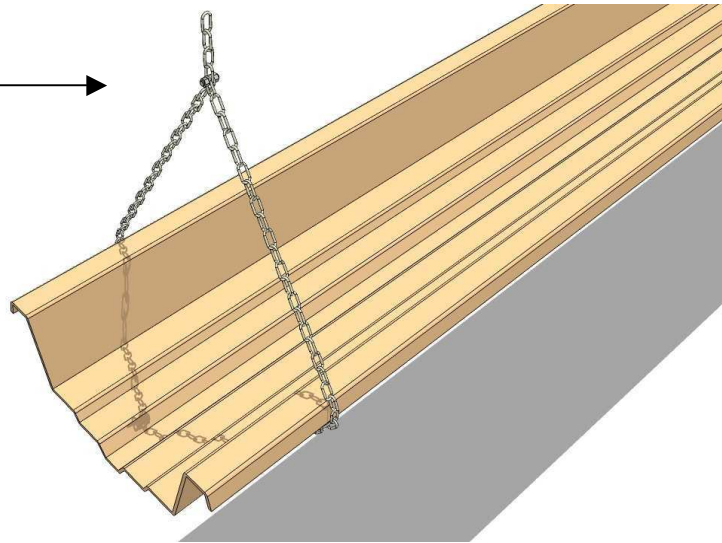
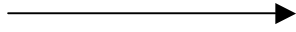

Place chain unit every 1.33 meters around the PVC gutter



MAPAL'S PVC 110 STANDING SYSTEM



The grower can set up a standing system with legs to sustain the PVC 110 troughs, the same rules and requirements apply:

1. The gutter should have a 1.5% slope
2. There should be a support column every 1.33 meters



MAPAL'S PP CONTAINERS FOR THE PVC 110 GUTTER (OPTIONAL)

Mapal offers polypropylene containers that fit neatly in the 110 PVC Gutter and which can be filled with any substrate including grow bags.

These containers allow for a high plant density with a minimum substrate volume per plant.

The containers allow for good aeration, easy and effective spraying, Reduces evaporation, and of course does not allow contact between fruit and substrate.

The containers are packed flat on pallets, for lower shipping costs and easy storage.

DIMENSIONS OF THE PP CONTAINER

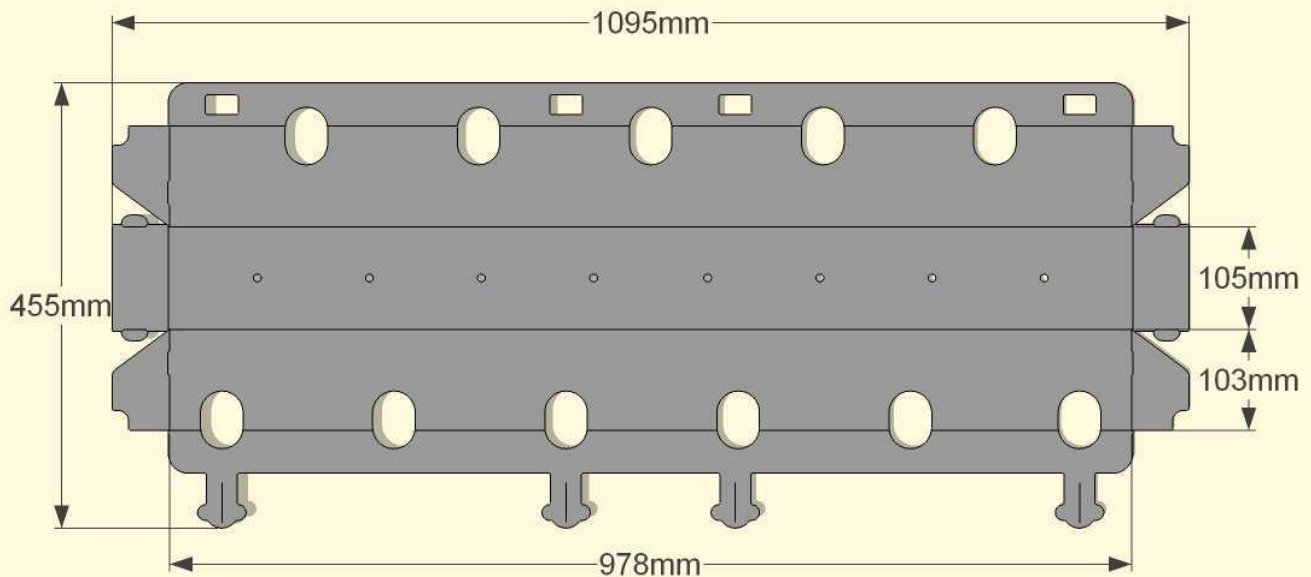

ASSEMBLY OF THE PP CONTAINER

The polypropylene container is easy to assemble: it arrives flat on pallet (A), just fold at the crease (B) and over lace the tongues(C). The container holds its' shape very well and is sturdy.

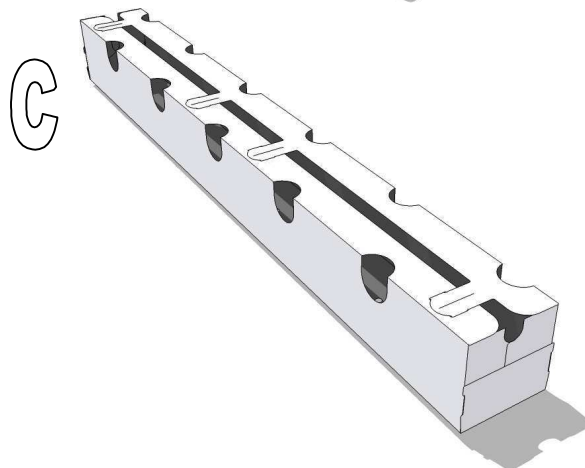
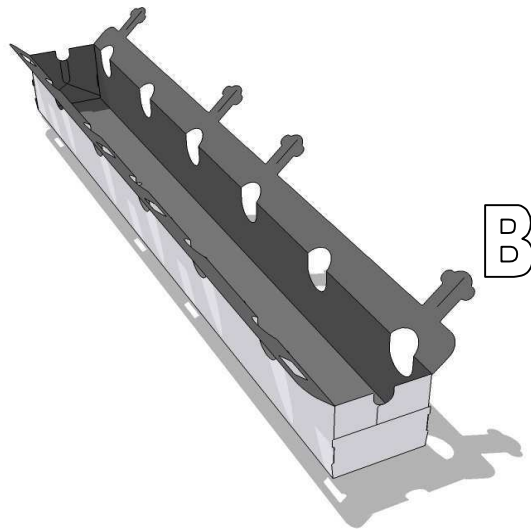
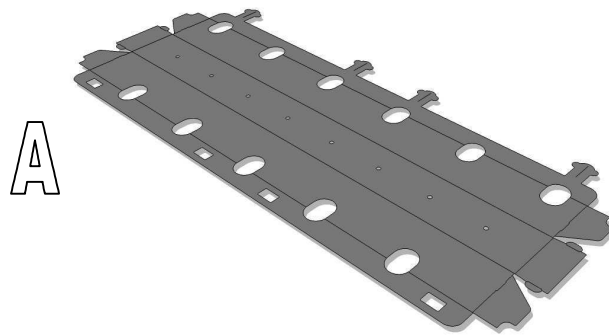

THE DRAINAGE COLLECTION SYSTEM FOR THE PVC 110 GUTTER

MAPAL offers a drainage outlet that can be attached at the end of the PVC gutter

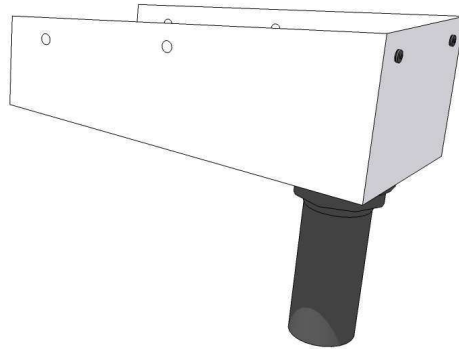

The drainage outlet is supplied flat (A).
It is easy to fold along the creases and add the rivets (B).

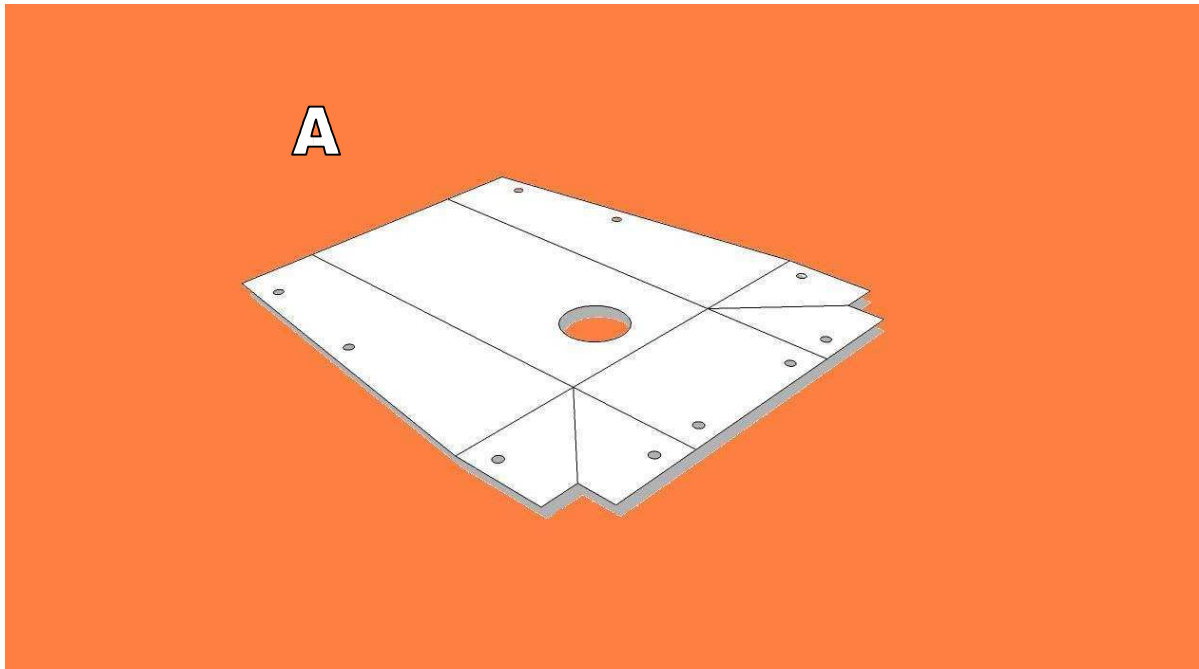

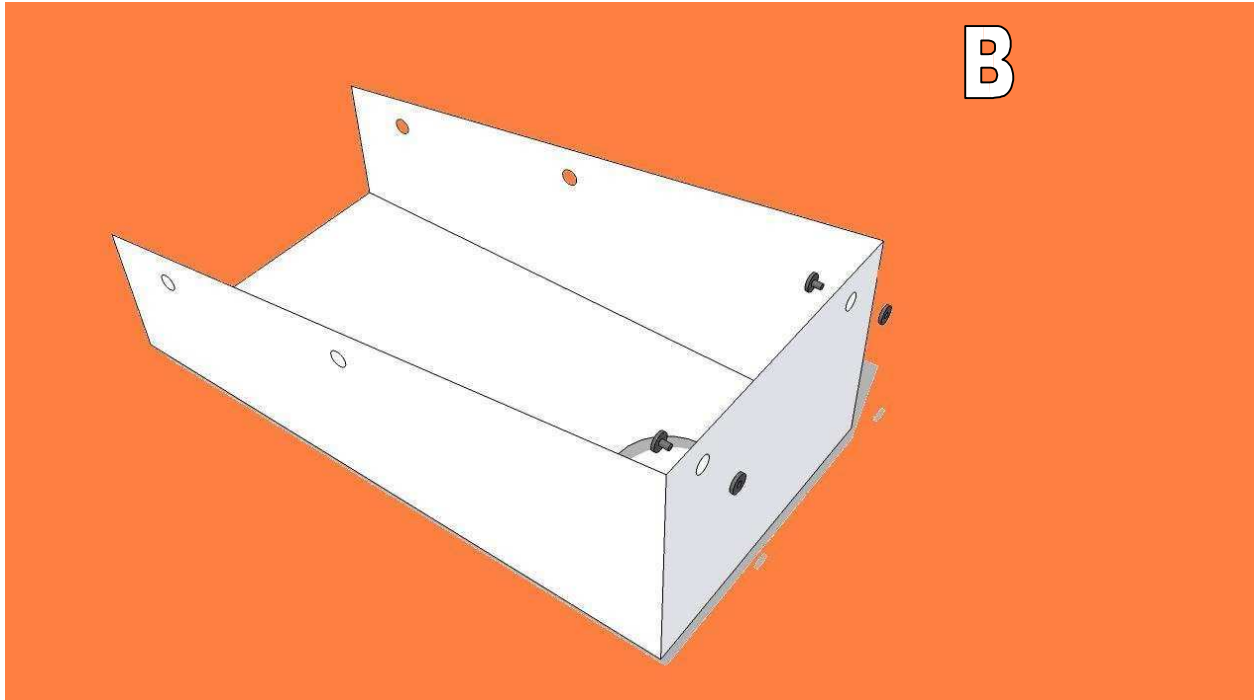

Once you have assembled the end unit you can add to **it the 1 1/4" outlet drainage unit (D).**

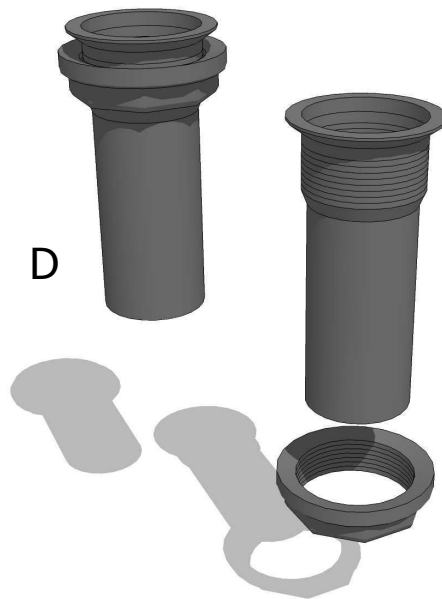

The assembly is easy and quick (E & F) just insert and close the plastic drainage unit.

E

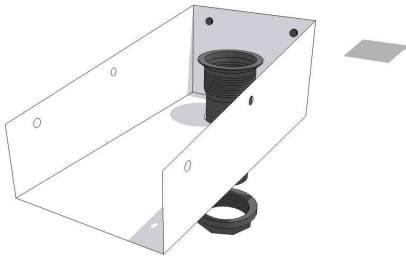

F

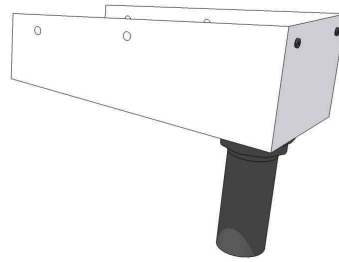

THE FULL PVC 110 MAPAL GUTTER SYSTEM

To connect the end unit to the PVC110Gutter:

Drill holes, from the inside out, in the PVC gutter in the appropriate location, and join the unit to the PVC gutter using plastic rivets or screws.

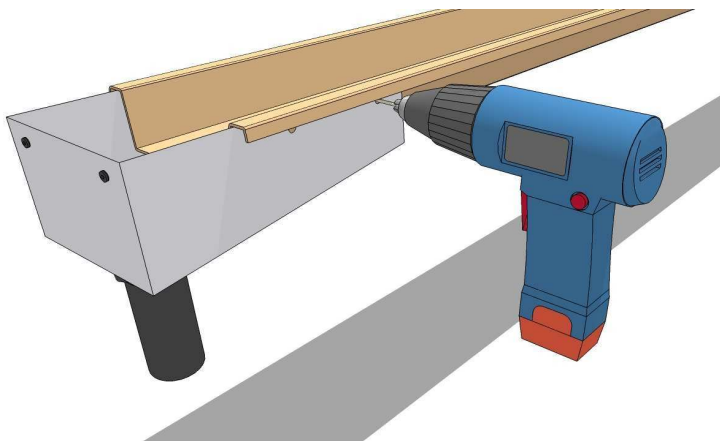

Place the open PP container in the PVC gutter

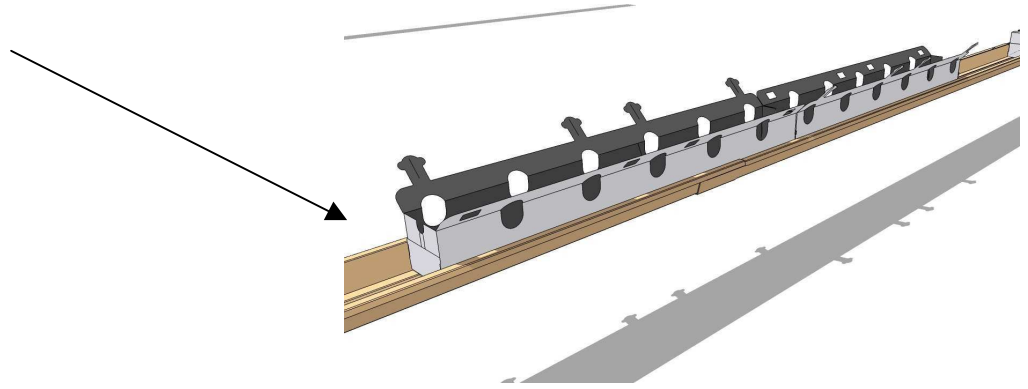

Substrate

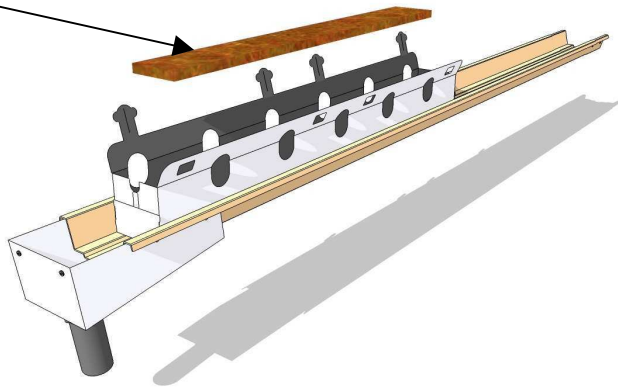

Place substrate inside the container and leave the top open for planting

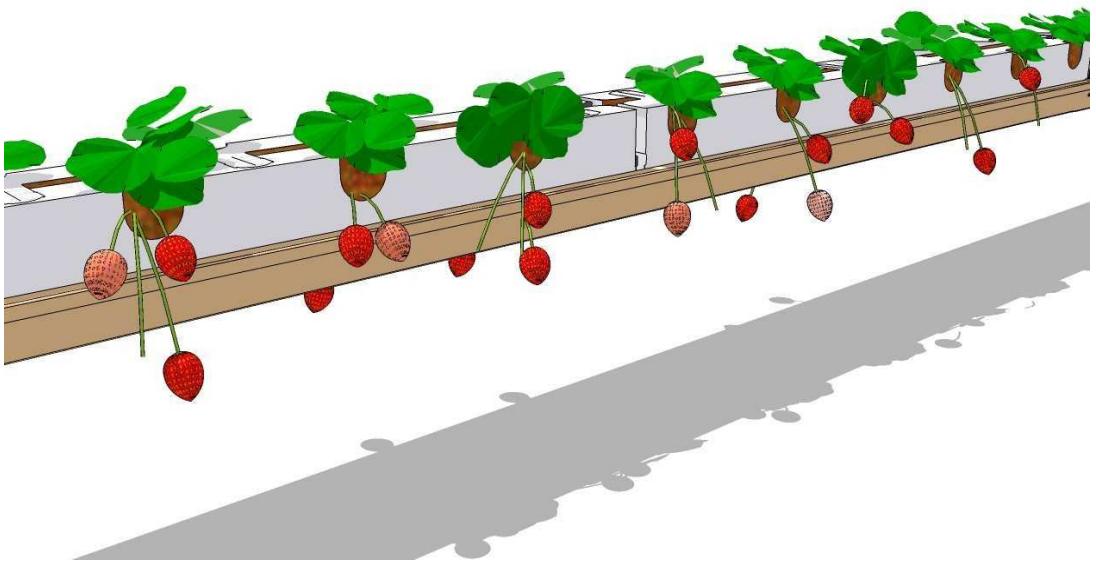

UNLOADING AND STORAGE OF THE PVC GUTTERS



To reduce the risk of damaging the PVC drainage gutters supplied by Mapal you must comply with the following instructions:

The PVC drainage gutters should be stored in a manner similar to what you have received in the package.

1. When you open the container, make sure that the PVC drainage gutters are not damaged, bent, broken or twisted, and that they sit on top of each other in a straight line. If there are any problems, please send photos along with the order and container number.
2. Prepare a considerable flat area for placing the PVC drainage gutters.
3. When removing the PVC gutters from the container, place one above the other, as they were in the container. The PVC gutters should be handled manually not pulled or machine handled when being removed from the container. With 11.7 meters long gutters one must be even more vigilant.

4. You should not throw or drop the PVC gutter, especially at a temperature below 10°C/50°F.
5. During the storage of PVC gutters, they should be on top of each other in a stable stack.
6. In warm weather, with temperatures reaching 95°F/35°C, PVC gutters should be stored away from direct sunlight, in the shade or covered so as not to reach too high a temperature. While in storage, PVC gutters can be damaged by exposure to extreme heat.
7. Any other changes made to the PVC gutters should be done in such a way that the gutters stay straight at all times.

STORAGE BETWEEN GROWING SEASONS

Once the growing season is over and the greenhouse is cleaned up, it is of the outmost importance to take good care of the PVC gutter.

When the grower leaves the PVC set up in the greenhouse:

The temperature in the greenhouse should not exceed 40°C to this purpose we recommend allowing ventilation through open windows or any other outlet.

If you are using grow bags, they can be left in the PVC gutter until the next growing season set up.

IMPORTANT THINGS TO ALWAYS KEEP IN MIND

Never leave the greenhouse closed when not in use.

It is essential to follow the instructions regarding the care of the PVC 110 gutter and to make sure that it is not in direct sunlight or in a closed area (without ventilation) where temperatures can reach 44 degrees and above.

Do not leave the PVC in above 44 degree or higher heat environment

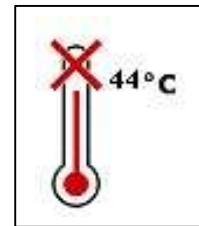

Do not drop or throw the PVC Gutters

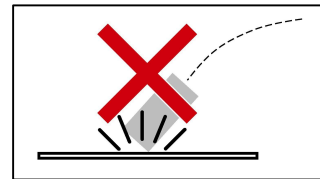

Do not leave the PVC Gutters exposed to direct sunlight

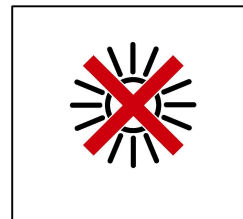

Warning:

If the grower does not follow the instructions, the PVC 110 gutter might suffer irreparable damage.

Mapal does not take responsibility and will not be held liable for damage incurred to the PVC 110 gutter due to faulty care by the customer.

PVC 110 GUTTER SYSTEM RECOMMENDATIONS

A slope of 1.5% is required for the system to be effective.

The grower should allow a drainage outlet every 35 meters.

The correct use of the recommended adhesive (PVC adhesive) Is crucial to the success of the project.

Placement of the screws or rivets on the PVC gutter connections is very important to strengthen and stabilize the PVC gutter.

When in doubt you can always contact Mapal for Technical advice or enter our web site (<http://www.mapalagro.com>) to download instructional Pdfs.

MAPAL
AGRICULTURE PRODUCTS DIVISION
MEVO HAMMA, 1293400 ISRAEL
Tel: +972-4-6764754/ 554/ 555
Cell: +972 -52-8695370
Fax: +972-4-6764756

Rubzvi@mapalplastics.com
Danny@mapalplastics.com
Mapal@mapalplastics.com

WEB: <http://www.mapalagro.com>



GLUE MANUFACTURERS AND RECOMMENDED GLUES

Europe & the Middle East

From Israel, **Adhestick** produces many glues from which we recommend the usage of the "G-PVC" adhesive.

www.adhestick.com

Europe & America

HENKEL manufactures glue we recommend: "TANGIT".

www.henkel.com

United States

WELDON, from the United States produces "PVC-CEMENT 719" which can also be used as a PVC adhesive.

<http://www.ipscorp.com/weldon/>

PVC110CONNECTIONGUTTERADHESIVE&SEALER **G-PVC/2**

Description:

High viscous PVC adhesive for bonding and sealing of rigid PVC Gutters for use in agriculture for the "Soilless Growing Systems".

Features:

Durable fast drying constructive adhesive, intended for long-term use in extreme weather conditions. Water and chemical resistant, it's easy to apply with a squeezable bottle.

Bonds:

Rigid and semi rigid PVC, C-PVC, U-PVC.

Physical Properties:

Base: Synthetic copolymers.

Viscosity: 17000 CPS \pm 2%. Solid

contents: 30% \pm 2%. Specific

gravity: 1.01 gr. /cm³. Flash

point: -20°C.

Bonding range: 1- 24 hours.

Coverage: 20-30 gr. per
connector. Color: Light blue.

Cleaning and diluting: Adhestick G-PVC

Thinner. Storage: 12 months at 20°C.

Packaging: 1 liter PE squeezable bottle.

Material Safety Data Sheet (MSDS)

G-PVC

1. Chemical Product and Company Identification

Identification of the substance:

Adhesive. UN No: 1133

Emergency action code:

3(Y) E Stationary phase:

Liquid. Manufacturer:

Adhestick Ltd.

17 Hamelacha St. Afek Industrial Park, Rosh Ha'ain 48091

ISRAEL

Tel: 972-03-9027080

Fax: 972-03-9027077

2. Composition \ Information on ingredients:

Description: Adhesive.

Dangerous components:

	CAS No	R-Phrases
T.H.F.	109-99-9	R11, R36/37,
Cyclohexanone	108-94-1	R10, R20

3. Hazards Identification

Highly Flammable.

Irritating to eyes and respiratory system. May form explosive peroxides.

Adverse human health effects:

Anesthetic effects

May affect the nervous system causing headache, possibly dizziness, nausea, weakness, loss of co-ordination and unconsciousness. This material or its emissions may cause damage to kidneys and liver and/or aggravate existing disorders.

Inhalation:

When heated, material emits irritating vapors, affecting the respiratory tract and other mucous membranes.

Symptoms include nausea, sleepiness, headache, dizziness, and anesthetic effects.

Skin contact:

May produce skin irritation.

Repeated or prolonged skin contact may cause dermatitis and defatting.

Eye contact:

When heated, material emits highly irritating vapors, affecting the eyes.

Ingestion:

See inhalation.

4. First Aid measures

General: Take off immediately all contaminated clothing.

Inhalation: if vapor is inhaled in high concentrations, take the person into the fresh air and keep him warm, let him rest. If there is difficulty in breathing, medical advice is required.

Skin contact: After contact with skin, wash immediately with plenty of water and soap.

Eye contact: Rinse opened eye for several minutes under running water. If symptoms persist, consult a doctor.

Swallowing: DO NOT induce the patient to vomit, seek medical advice.

5. Fire fighting measures

Extinguishing media: CO₂, foam, dry powder. Apply water spray or fog to cool nearby equipment.

Unsuitable: Water may be ineffective in firefighting.

Dilation with water may not be sufficient to raise the flash point above the ambient temperatures.

Personal precautions: Use self-contained breathing apparatus when in close proximity to fire. Fight fire from safe distance and protected location.

6. Accidental release measures

Personal precautions: Evacuate and limit access. Keep away from sources of ignition- No Smoking.

Put on protective equipment. Cover with damp. Fluid – binding material (sand, sawdust, chemical binder based on calcium silicate hydrate). Transfer to waste container after approx. 1 hour and do not seal (CO₂ formation). Keep damp and in the open air in a safe place for 7 to 14 days.

7. Handling and Storage

Handling:

Information for safe handling:

Ensure good ventilation\ exhaust at the workplace. Ensure good interior ventilation, especially at floor level. (Fumes are heavier than air).

Information about fire-and explosion protection:

Keep ignition sources away –Do not smoke.
Protect against electrostatic charges.

Storage:

Requirements to be met by storerooms and replaces:

Store in a cool location.

Further information about storage conditions:

Keep receptacle tightly sealed.
Store in cool, dry conditions in well-sealed receptacles.

8. Exposure Controls \ Personal Protection

Respiratory protection: Unless the product is entirely enclosed, do not handle it until you have studied the respiratory precautions issued by the appropriate authority or accident prevention association. Full mask with filter is recommended.

Hand protection:

protective gloves for chemicals made out of PVC.

Eye protection:

Goggles\ face protection.

Keep working clothes separate. Wash hands before breaks and at end of work.

Exposure limits:

The product may be detectable by odor below one tenth of the TLV (Threshold Limit Value).

TLV –TWA [mg/m³] : 590

TLV –TWA [ppm] : 200

TLV –STEL [mg/m³] : 737

TLV –STEL [ppm] : 250

9. Physical and chemical properties

Form: Liquid.

Color: transparent

yellow. Odor: ethereal.

Boiling point:

66°C Flash

point: -20 °C

Density: 0.92 -0.94 gr /cm³ (at

20°C) Viscosity: 28,000CPS (at

23°C)

Solubility in water: Not miscible or difficult to mix.

10. Stability and reactivity

Hazardous polymerization: May occur in the presence of cationic initiators such as strong proton acids or selected Lewis acids.

Stability: Stable with an appropriate level of inhibitor, but reactive (unstable) without.

May form explosive peroxides.

Materials and conditions to avoid (incompatibility): It is explosive with potassium hydroxide, sodium hydroxide and sodium tetrahydroaluminate, since caustic alkalis deplete the inhibitors.

11. Toxicological information

Toxicity by ingestion LD50 (mg/kg): 3000 (rat)

Inhalation: Vapor concentrations above recommended exposure levels may be irritating to the eyes and the respiratory tract, may cause headaches and dizziness, could be anesthetic and may have other central nervous system effects.

Skin contact:

May produce skin irritation. Repeated or prolonged skin contact may cause dermatitis and defatting.

Eye contact:

Will cause eye discomfort, affecting the eyes.

Ingestion:

Small amount of liquid aspirated into the respiratory system during ingestion or from vomiting may cause bronchopneumonia or pulmonary edema.

12. Ecological information

Ecological effects information: Treated effluent may be biodegradable. Persistence and degradability: If the compound is released to Atmosphere: the substance Photo degrades.

13. Disposal considerations

Disposal: Incinerate liquid residues and solids used as spillage absorbents. (Dispose only

By approved contractors following regulations covering disposal of these materials).

14. Transport information

AIR (ICAO/IATA)

ADR/RID class: 3 Flammable

liquids. Class: 3

UN Number: 1133

Label: 3

Proper shipping name: Adhesive; containing flammable liquid. Maritime transport IMDG:

Class: 3

UN Number: 1133

Label: 3

Proper shipping name: ADHESIVES

15. Regulatory information

Hazard symbol(s):

Highly flammable.

Irritant.

R Phrase(s):

R11- Highly flammable

R19- May form explosive peroxides.

R36/37 – Irritating to eyes and respiratory system. R 20- Harmful by inhalation.

S Phrase(s):

S16 – Keep away from sources of ignition – No smoking. S29 – Do not empty into drains.

S33 – Take precautionary measures against static discharges.

S 25- Avoid contact with eyes.

16. Other information

The information here in was gathered from the raw materials suppliers. It is the duty of the user to verify the data and use the product responsibly as per his requirements and the Producers instructions.

Adhestick LTD or its employees

Will not be held responsible for any damage caused by the use of this information and/or the product.



MAPAL
AGRICULTURE PRODUCTS DIVISION
MEVO HAMMA, 1293400 ISRAEL
Tel: +972-4-6764754/ 554/ 555
Cell: +972 -52-8695370
Fax: +972-4-6764756

Rubzvi@mapalplastics.com
Danny@mapalplastics.com
Mapal@mapalplastics.com

WEB: <http://www.mapalagro.com>