



MAPALS' PVC 210

GUTTER SYSTEM



INTRODUCTION

MAPALS' PVC 210 GUTTER SYSTEM

The Mapal PVC 210 Gutter is an innovative product of Mapals' Agricultural Division, created to successfully compete against the different metal gutters available.

Mapal PVC 210 Gutter is a more cost effective alternative. It is durable, strong, multifunctional, adjustable and much lighter than metal (which is very important in old green house structures).

Mapals' PVC gutter can be used with Mapals' PP containers or/and any grow bag (perlite, coco peat, rock wool, Peat) or any other kind of substrate.

Mapal also offers a full system which includes the PVC gutters, growing troughs, drainage systems, hanging units metal stands or adjustable metal stands.

The multi-functionality of Mapals' system allows the growers more flexibility in the decision making process regarding their crops and how to grow them.

PVC 210 GUTTER DIMENSIONS

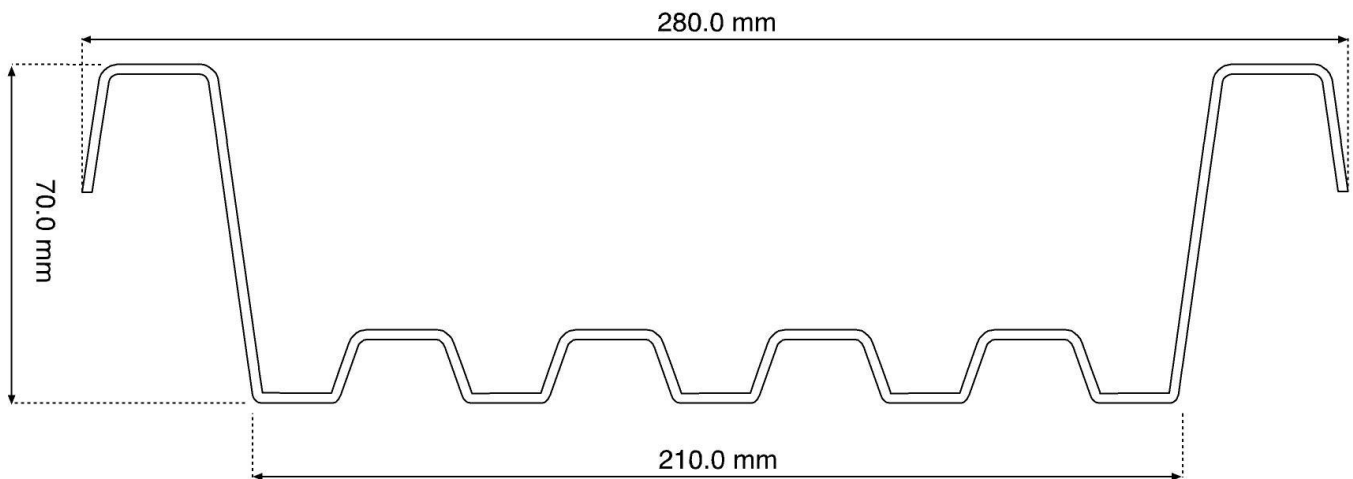

PVC 210 GUTTER

The PVC 210 Gutter is offered in 5.85 Meter length which fits in a 20 foot container

The maximum recommended length of a growing gutter, using the PVC 210 Gutter, is for up to 35 -45 Meters per bed. When the row is longer, we suggest cutting the gutter into sections to allow better drainage collection conditions.

PVC 210 GUTTER CONNECTIONS

MAPALS' PVC Gutter's added feature of indentation at the end of every gutter allows for an easy and clean fit.

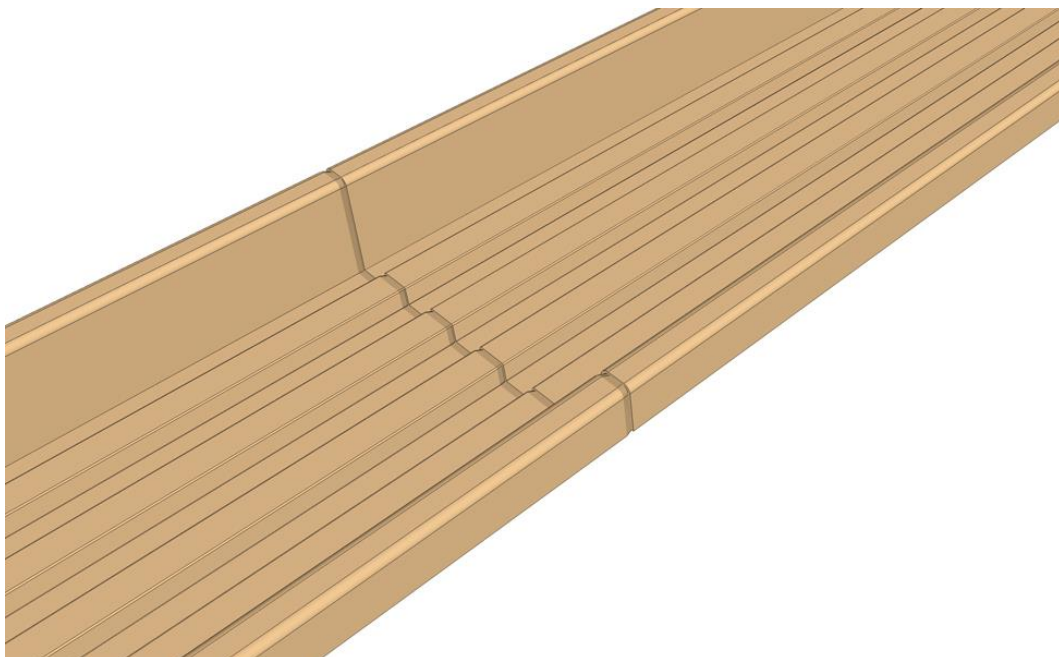
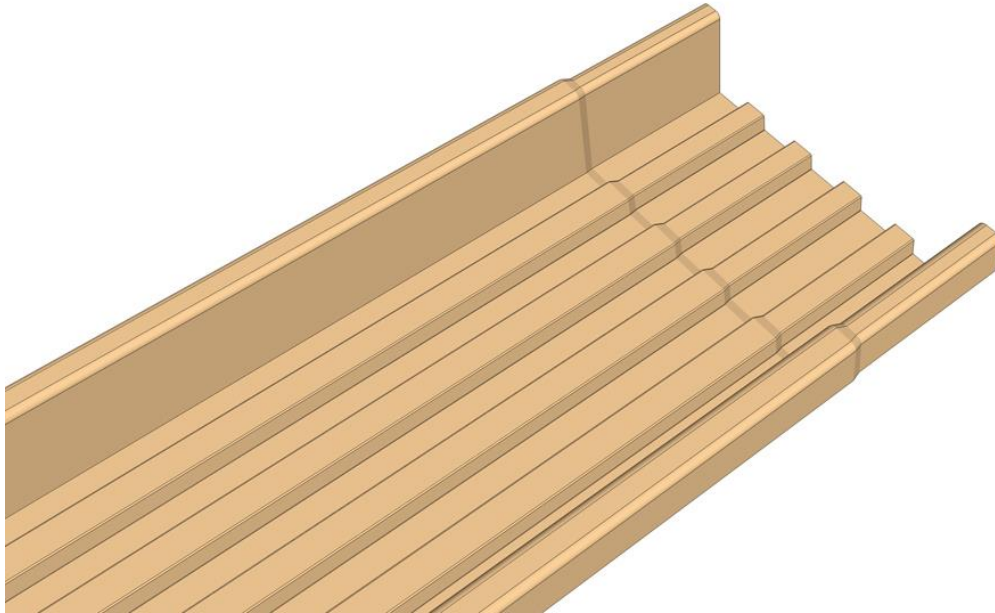

PVC 210 CONNECTION GUTTER ADHESIVE & SEALER G-PVC/2

Description:

High viscous PVC adhesive for bonding and sealing of rigid PVC Gutters for use in agriculture for the "Soilless Growing Systems".

Features:

Durable fast drying constructive adhesive, intended for long-term use in extreme weather conditions. Water and chemical resistant, it's easy to apply with a squeezable bottle.

Bonds:

Rigid and semi rigid PVC, C-PVC, U-PVC.

Physical Properties:

Base: Synthetic copolymers.

Viscosity: 17000 CPS $\pm 2\%$.

Solid contents: 30% $\pm 2\%$.

Specific gravity: 1.01 gr./cm³.

Flash point: -20°C.

Bonding range: 1- 24 hours.

Coverage: 20-30 gr. per connector.

Color: Light blue.

Cleaning and diluting: Adhestick G-PVC Thinner.

Storage: 12 months at 20°C.

Packaging: 1 liter PE squeezable bottle.

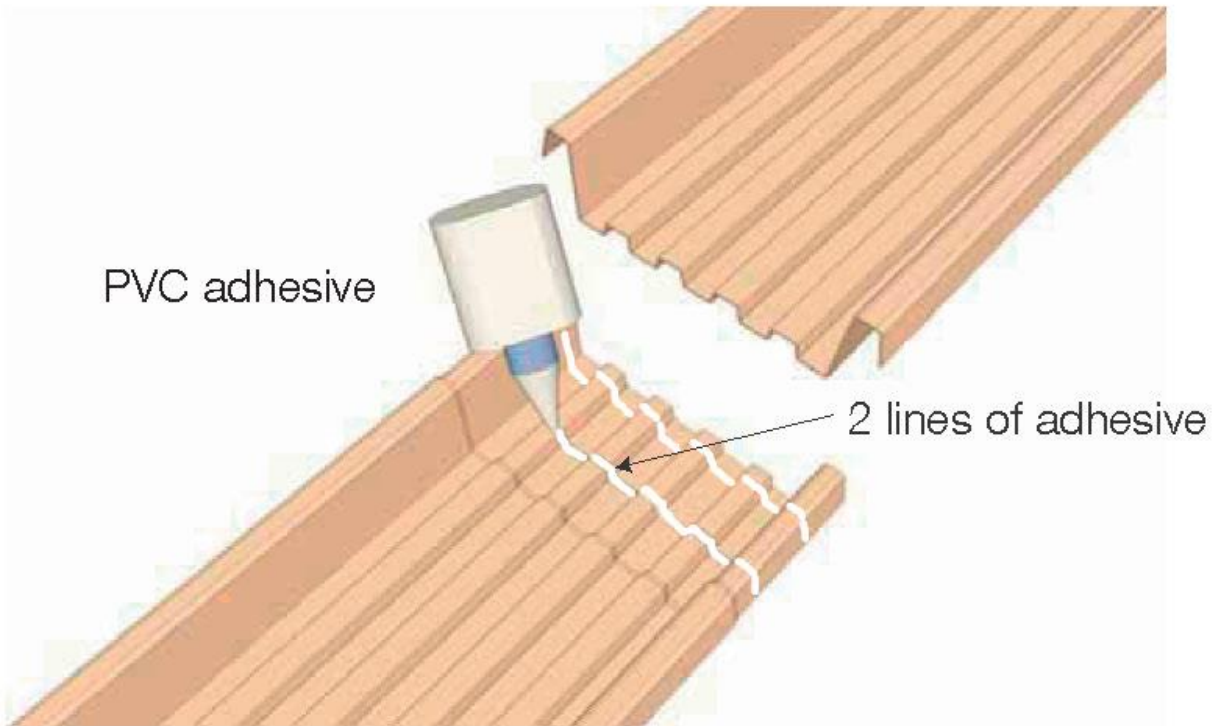

Application information:

1. Surfaces must be dry, clean and dust free.
2. Apply two uniform layers of adhesive on one side and glue together within a short period of time. Add a third line of adhesive on the inside connection to ensure there is no leakage (see drawing).

3. **Apply constant pressure while drying.**

This can be achieved by drilling the screws or inserting rivets in the designated areas while the glue is still setting (see drawing below).

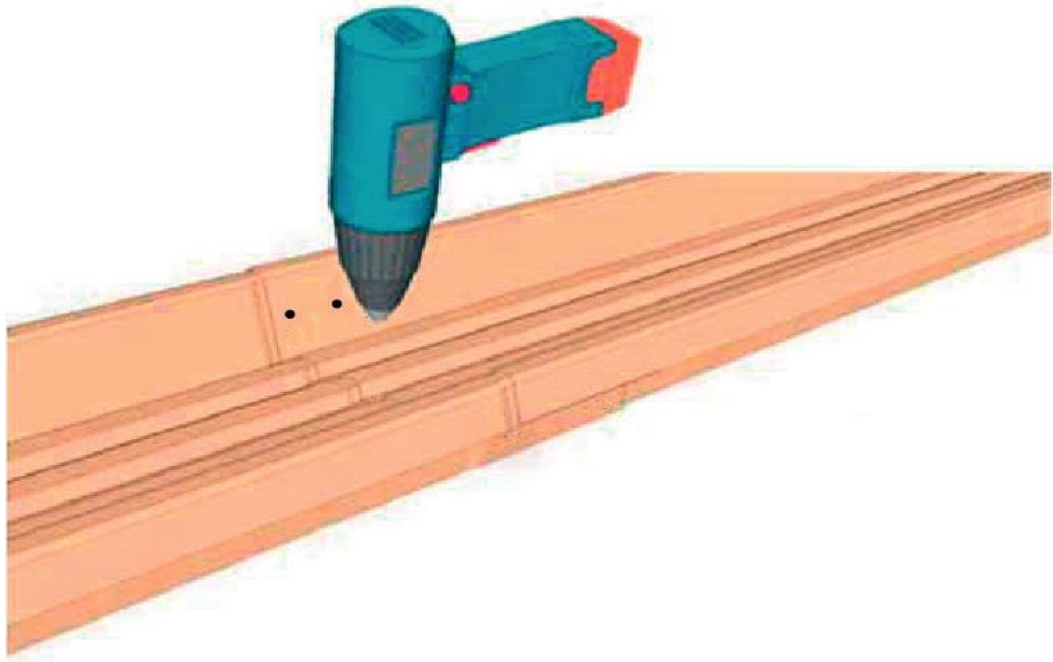

Screw 2 wide-headed metal screws or rivets on both sides from the inside

The gutters must be assembled, glued and rivets or screws drilled in while the PVC gutters lie on a straight level surface.

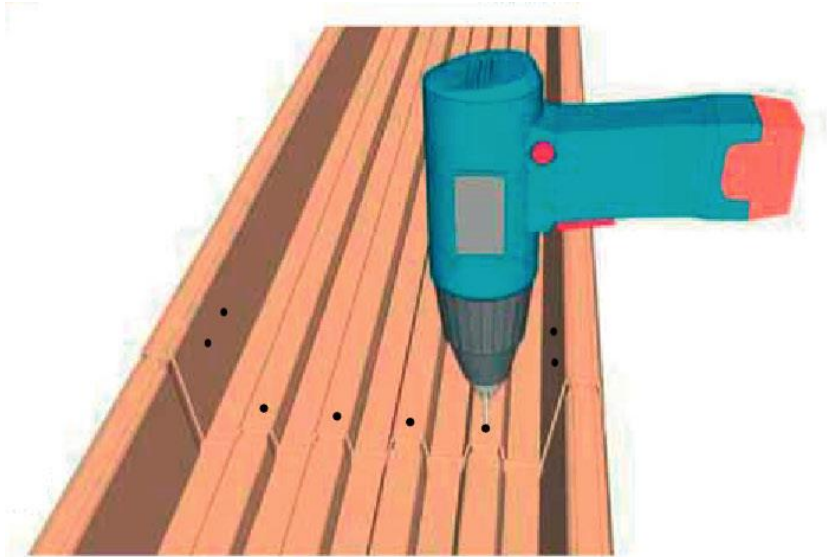

Screw 4 wide-headed metal screws or rivets on top of 2 inside upper parts

Do not attempt to apply pressure with other objects.

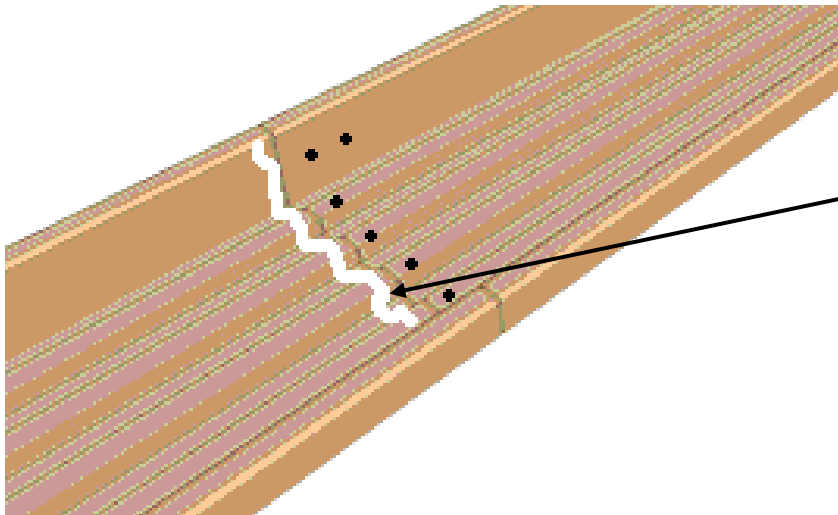

The additional line of PVC adhesive will ensure that there is no leakage

4. **Let dry for 24 hours**, before moving or hanging.
5. After drying, the adhesive layer continues to strengthen.
6. Clean hands with Acetone.

Precautions:

7. Refer to Material Safety Data Sheet before using this product.

IMPORTANT THINGS TO ALWAYS KEEP IN MIND

Never leave the greenhouse closed when not in use.

It is essential to follow the instructions regarding the care of the PVC 210 gutter and to make sure that it **is not** in direct sunlight or in a closed area (without ventilation) where temperatures can reach 40 degrees and above.

Do not leave the PVC in above 44 degree or higher heat environment

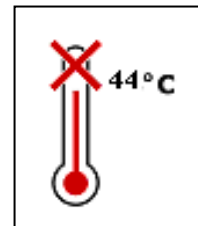

Do not drop or throw the PVC Gutters

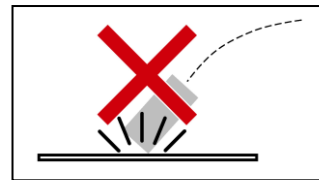

Do not leave the PVC Gutters exposed to direct sunlight

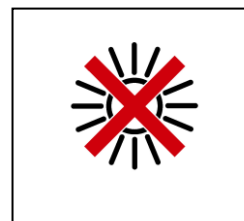

Warning:

If the grower does not follow the instructions, the PVC 210 gutter might suffer irreparable damage.

Mapal does not take responsibility and will not be held liable for damage incurred to the PVC 210 gutter due to faulty care by the customer.

PVC 210 GUTTER SYSTEM RECOMMENDATIONS

A slope of 1.0-1.5% is required for the system to be effective.

Mapals' PVC 210 Gutter system is multi-functional because it can be used for either hanging or standing and can also be used either in a **U** or an **∩** shape.

This array of possibilities allows the grower more flexibility in the decision making and planning of the crops and how to grow them.

Mapal offers the necessary accessories to facilitate the use of the systems.

The grower should allow a drainage outlet every 30-45 meters.

The correct use of the recommended adhesive (PVC adhesive) It is crucial to the success of the project.

Placement of the screws or rivets on the PVC gutter connections is very important to strengthen and stabilize the PVC gutter.

When in doubt you can always contact Mapal for Technical advice or enter our web site (<http://www.mapalagro.com>) to download instructional Pdfs.

MAPAL AGRICULTURAL DIVISION

rubzvi@mapalplastics.com

erick@mapalplastics.com

mapal@mapalplastics.com

THE HANGING SYSTEM

The PVC 210 Gutter hangs with the grow bag sitting inside (A)

The PVC 210 Gutter hangs with the grow bag sitting on top (B)

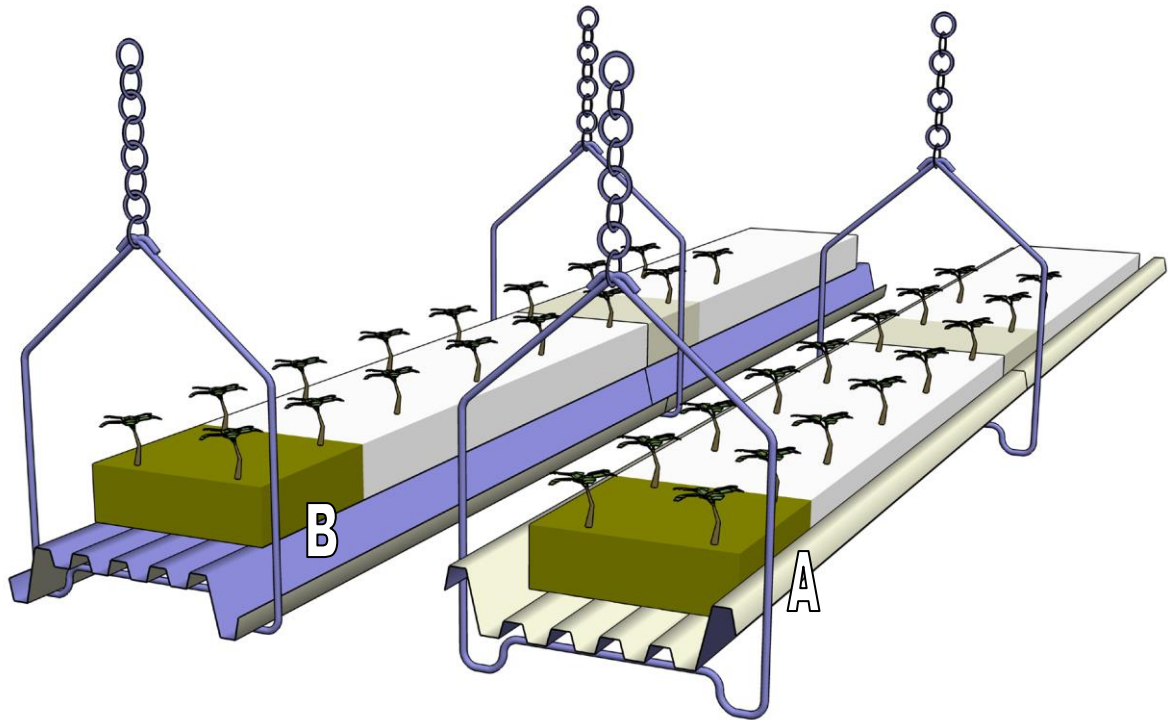

Mapal offers two kind of hanging units to be used with the PVC 210 hanging system:

When using the unit shown in the upper drawing (A), the drip pipeline can be put along one of the lower round bases of the metal hanging unit (picture 1, p.12).

HANGING UNITS

Description:

A Metal hanging unit, 5.8 mm in diameter, made of ASE 1040 material, galvanized

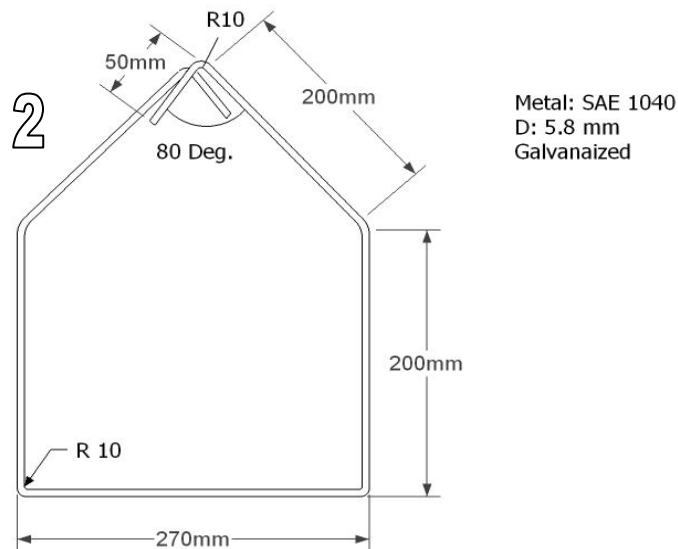
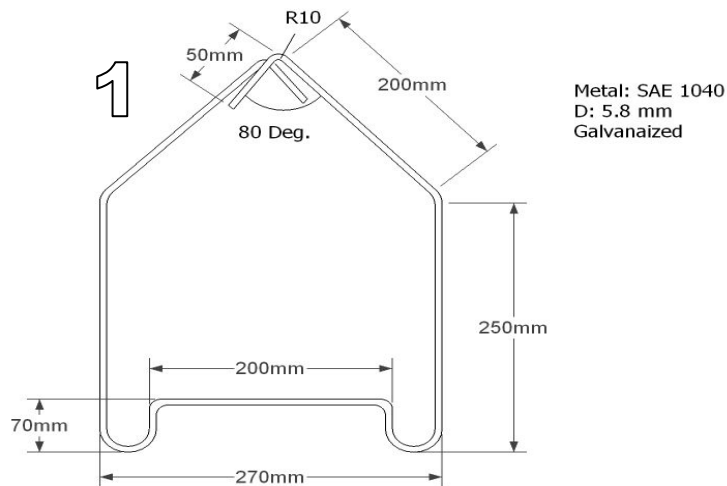

When using the gutter in the shape of a U:

It is also possible to use the second metal hanging unit (picture 2), when positioning the PVC gutter in the shape of U. This unit is less expensive yet lacks the advantage of having where to hang the drip pipeline.

When using the gutter in the shape of a \cap (the inverse of the U):

When using the unit shown in the upper drawing (B), only the upper drawing (1) metal hanging unit fits and can be used.

The **Maximum** distance between the hanging units, along the gutters, is of 1.25 meter.

For the hanging system one can preferably use an Adjustable Galvanized Hook and Ring although it is possible to make adjustments using other methods

Adjustable Galvanized Hook and Ring

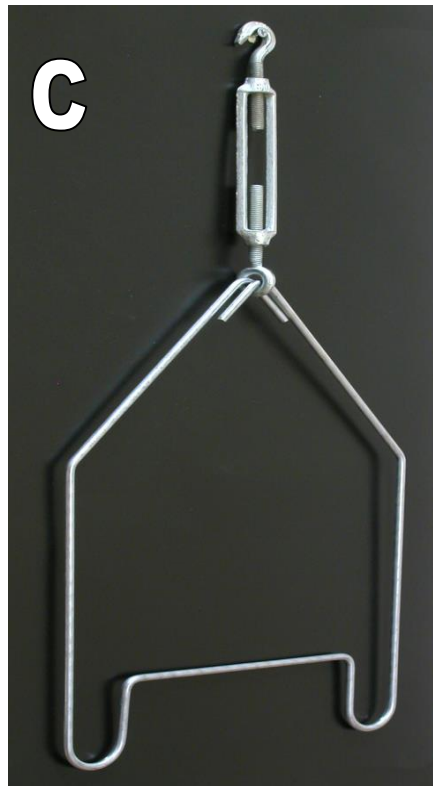

Properties description:

- M10 bolts with 100 mm adjustable length.
- Diameter in the inner hole of the Ring - Min. 12.5 mm.
- Both upper metal ends should enter inside the hole and hold the gutter, as seen in the picture.

- A Galvanized chain with a thickness of 3 or 4mm.

THE METAL STANDS SYSTEM

The gutter can be placed on metal stands, on solid ground, in either position (as seen in picture D).

The stands shown on picture D are offered in two different heights with which the slope cannot be manipulated.

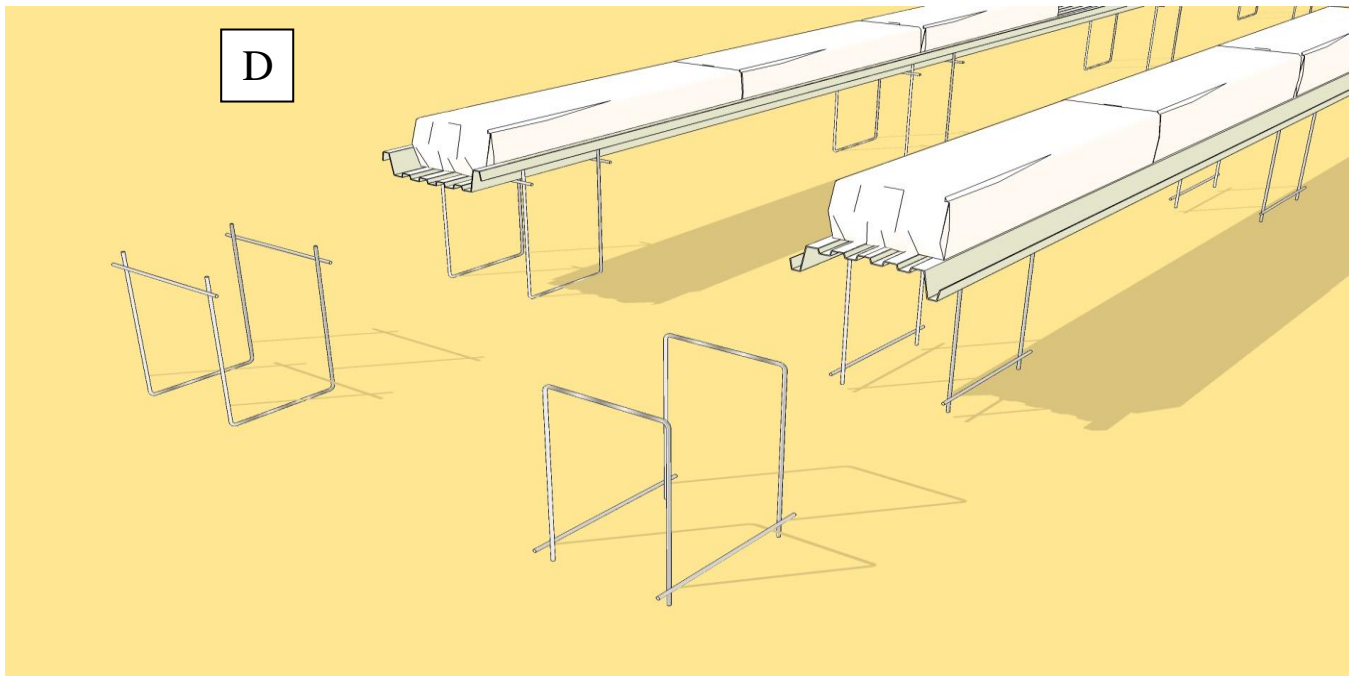

MAPAL'S New PVC gutter system requires a stand or hanging unit every 1.25 meter.

The PVC 210 Gutter on metal stands for the grow bag to be placed inside (A)

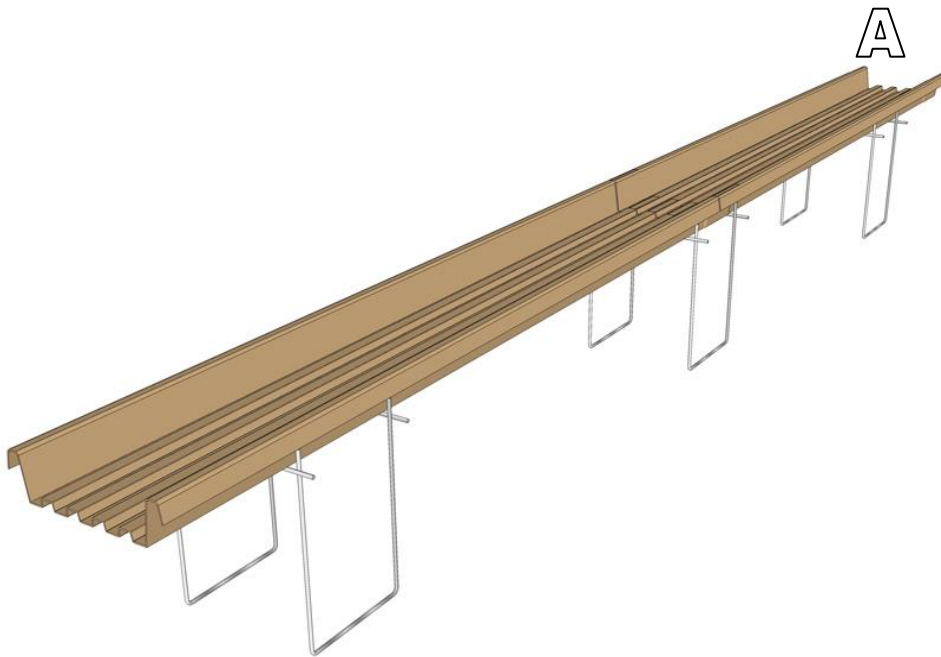

The PVC 210 Gutter on metal stands for the grow bag to be placed on top (B)

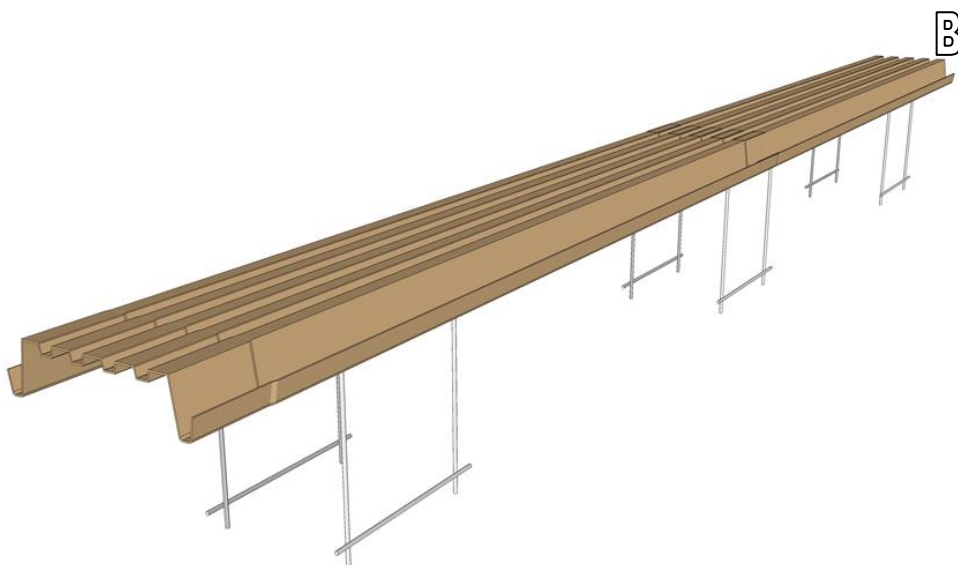

MAPALS GALVANIZED METAL STAND FOR PVC 210

Mapal's Galvanized Metal stand can be screwed into the ground because of the innovative tip at the end of the pipe.

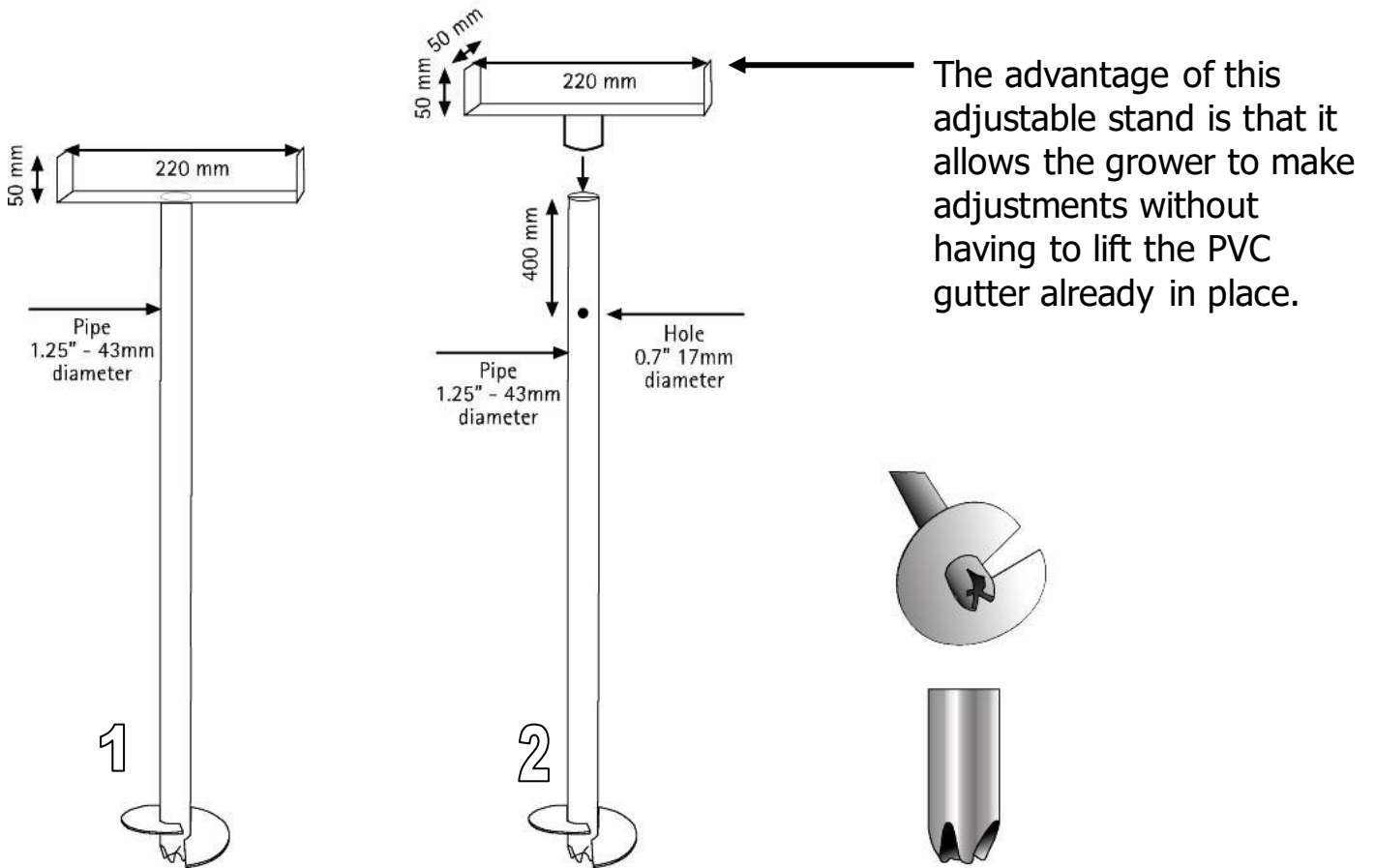

THE DRAINAGE SYSTEM FOR THE PVC 210 GUTTER

MAPAL offers a drainage outlet that can be attached at the end of the PVC gutter

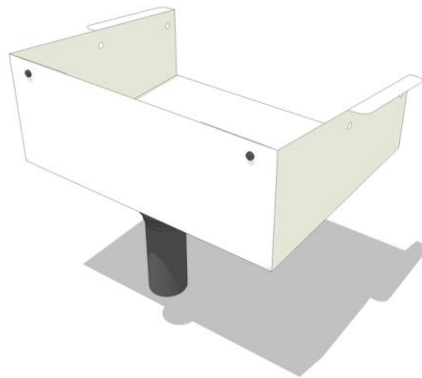

The drainage outlet is supplied flat (A).
It is easy to fold along the creases (B) and add the rivets(C).

A

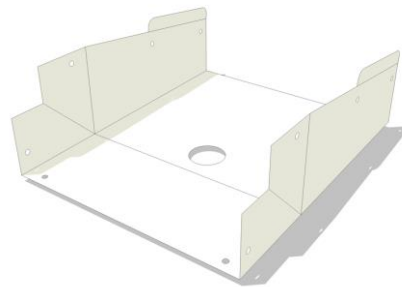
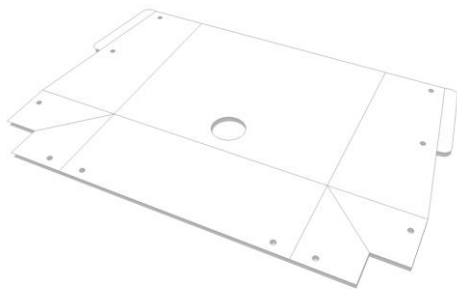

B

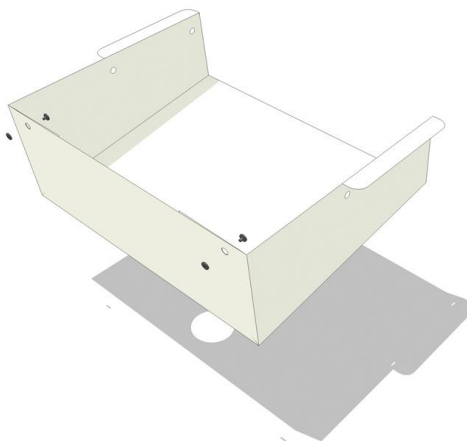

C

Once you have assembled the end unit you can add to it the **1 1/4" outlet drainage unit (D)**.

D



The assembly is easy and quick (E & F) just insert and close the plastic drainage unit.

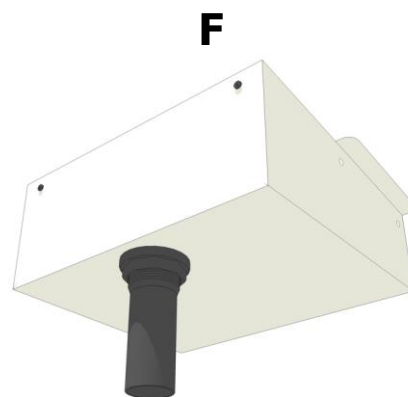
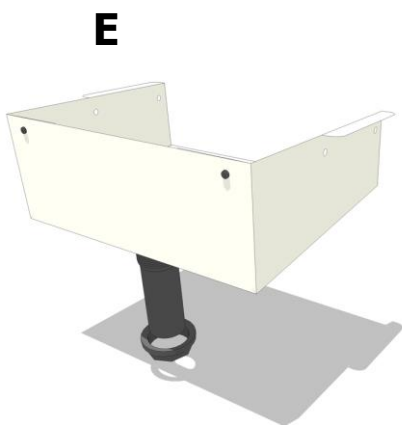

Drill holes in the PVC gutter in the appropriate location (A & B), and join the unit to the PVC gutter using plastic rivets or screws(C).

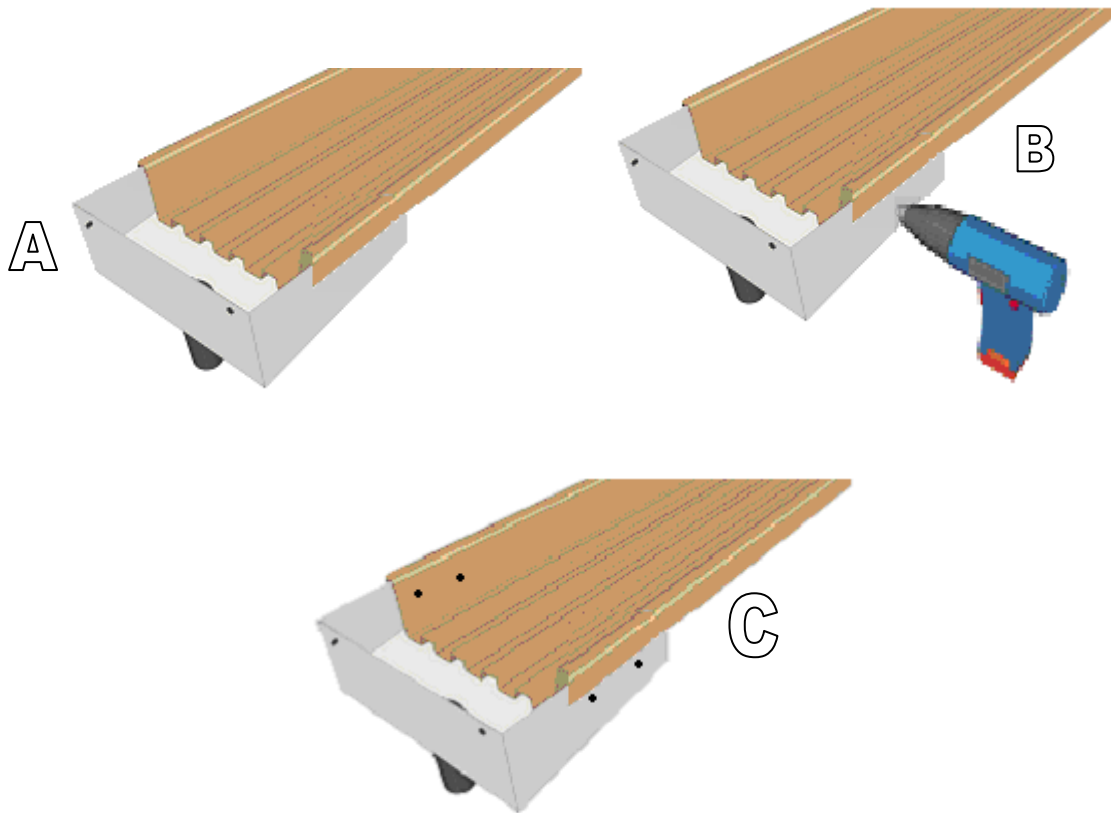

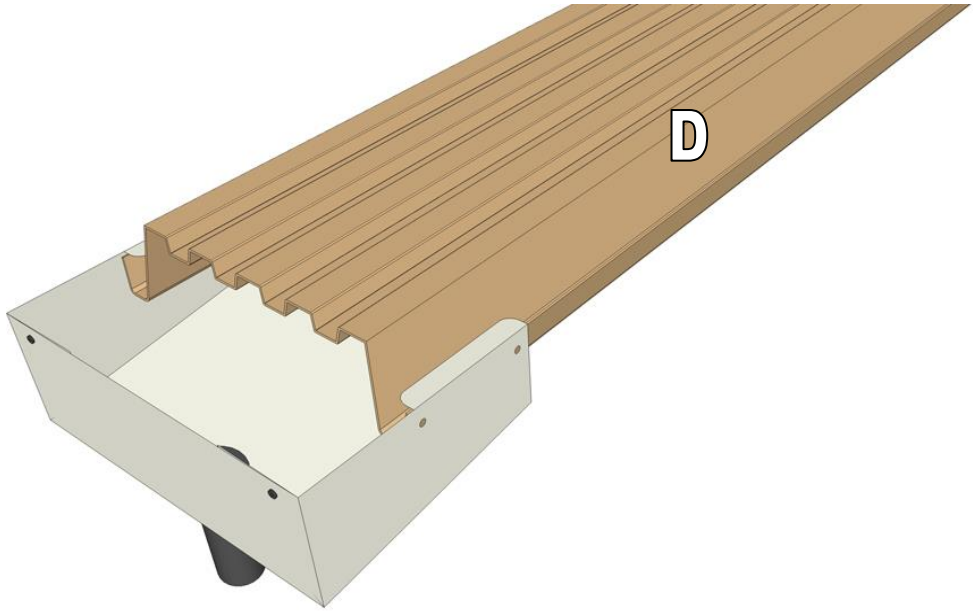

UNLOADING AND STORAGE OF THE PVC GUTTERS

In a 20 foot container one can load up to 12,500 running meter.
In a 40 foot container one can load up to 18,000 running meter because of a weight limit.

To reduce the risk of damaging the PVC drainage gutters supplied by Mapal you must comply with the following instructions:

The PVC drainage gutters should be stored in a manner similar to what you have received in the package.



1. When you open the container, make sure that the PVC drainage gutters are not damaged, bent, broken or twisted, and that they sit on top of each other in a straight line. If there are any problems, please send photos along with the order and container number.
2. Prepare a considerable flat area for placing the PVC drainage gutters.

3. When removing the PVC gutters from the container, place one above the other, as they were in the container. The PVC gutters should be handled manually, not pulled or machine handled when being removed from the container. With 11.7 meters long gutters one must be even more vigilant.

4. You should not throw or drop the PVC gutter, especially at a temperature below 10° C/50° F.

5. During the storage of PVC gutters, they should be on top of each other in a stable stack.

6. In warm weather, with temperatures reaching 95 ° F/35 ° C, PVC gutters should be stored away from direct sunlight, in the shade or covered so as not to reach too high a temperature. While in storage, PVC gutters can be damaged by exposure to extreme heat.

7. Any other changes made to the PVC gutters should be done in such a way that the gutters stay straight at all times.

STORAGE BETWEEN GROWING SEASONS

Once the growing season is over and the greenhouse is cleaned up, it is of the outmost importance to take good care of the PVC gutter.

When the grower leaves the PVC set up in the greenhouse:

The temperature in the greenhouse should not exceed 40 degrees; to this purpose we recommend allowing ventilation through open windows or any other outlet. If you are using grow bags, they can be left in the PVC gutter until the next growing season set up.

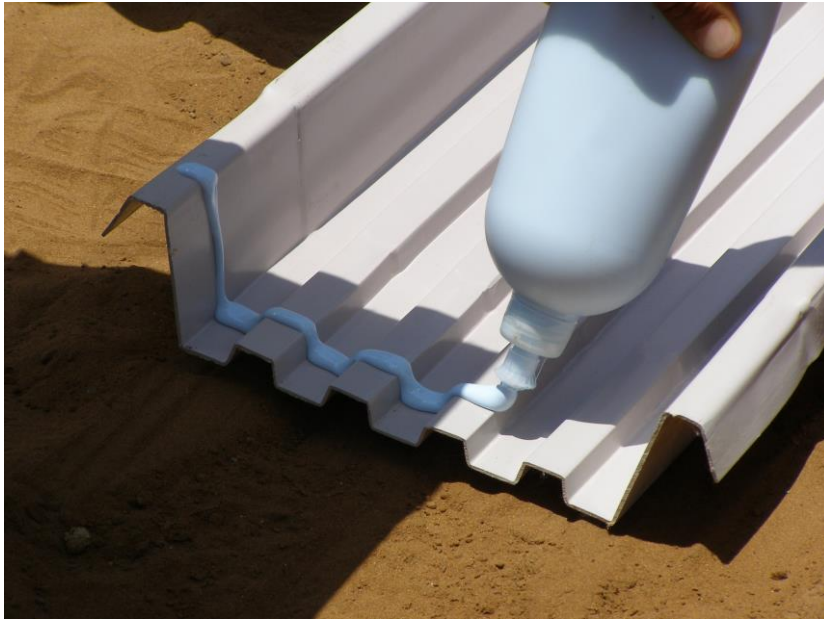

GLUE MANUFACTURERS AND RECOMMENDED GLUES

Europe & the Middle East

From Israel, **Adhestick** produces many glues from which we recommend the usage of the "G-PVC" adhesive.

www.adhestick.com

Europe & America

HENKEL manufactures a glue we recommend: "TANGIT".

www.henkel.com

United States

WELDON, from the United States produces "PVC-CEMENT 719" which can also be used as a PVC adhesive.

<http://www.ipscorp.com/weldon/>

Material Safety Data Sheet (MSDS)

G-PVC

1. Chemical Product and Company Identification

Identification of the substance: Adhesive.

UN No: 1133

Emergency action code: 3(Y) E

Stationary phase: Liquid.

Manufacturer: Adhestick Ltd.

17 Hamelacha St. Afek Industrial Park, Rosh Ha'ain 48091

ISRAEL

Tel: 972-03-9027080

Fax: 972-03-9027077

2. Composition \ Information on ingredients:

Description: Adhesive.

Dangerous components:

	CAS No	R-Phrases
T.H.F.	109-99-9	R11, R36/37, R19
Cyclohexanone	108-94-1	R10, R20

3. Hazards Identification

Highly Flammable.

Irritating to eyes and respiratory system.

May form explosive peroxides.

Adverse human health effects:

Anesthetic effects

May affect the nervous system causing headache, possibly dizziness, nausea, weakness, loss of co-ordination and unconsciousness. This material or its emissions may cause damage to kidneys and liver and/or aggravate existing disorders.

Inhalation:

When heated, material emits irritating vapors, affecting the respiratory tract and other mucous membranes.

Symptoms include nausea, sleepiness, headache, dizziness, anesthetic effects.

Skin contact:

May produce skin irritation.

Repeated or prolonged skin contact may cause dermatitis and defatting.

Eye contact:

When heated, material emits highly irritating vapors, affecting the eyes.

Ingestion:

See inhalation.

4. First Aid measures

General: Take off immediately all contaminated clothing.

Inhalation: if vapor is inhaled in high concentrations, take the person into the fresh air and keep him warm, let him rest. If there is difficulty in breathing, medical advice is required.

Skin contact: After contact with skin, wash immediately with plenty of water and soap.

Eye contact: Rinse opened eye for several minutes under running water. If symptoms persist, consult a doctor.

Swallowing: DO NOT induce the patient to vomit, seek medical advice.

5. Fire fighting measures

Extinguishing media: CO₂, foam, dry powder. Apply water spray or fog to cool nearby equipment.

Unsuitable: Water may be ineffective in firefighting.

Dilation with water may not be sufficient to raise the flash point above the ambient temperatures.

Personal precautions: Use self-contained breathing apparatus when in close proximity to fire. Fight fire from safe distance and protected location.

6. Accidental release measures

Personal precautions: Evacuate and limit access.

Keep away from sources of ignition- No Smoking.

Put on protective equipment. Cover with damp. fluid – binding material (sand, sawdust, chemical binder based on calcium silicate hydrate). Transfer to waste container after approx 1 hour and do not seal (CO₂ formation). Keep damp and in the open air in a safe place for 7 to 14 days.

7. Handling and Storage

Handling:

Information for safe handling:

Ensure good ventilation\ exhaustion at the workplace.

Ensure good interior ventilation, especially at floor level.

(Fumes are heavier than air).

Information about fire-and explosion protection:

Keep ignition sources away –Do not smoke.

Protect against electrostatic charges.

Storage:

Requirements to be met by storerooms and replaces:

Store in a cool location.

Further information about storage conditions:

Keep receptacle tightly sealed.

Store in cool, dry conditions in well sealed receptacles.

8. Exposure Controls \ Personal Protection

Respiratory protection: Unless the product is entirely enclosed, do not handle it until you have studied the respiratory precautions issued by the appropriate authority or accident prevention association. Full mask with filter is recommended.

Hand protection: protective gloves for chemicals made out of PVC.

Eye protection: Goggles\face protection.

Keep working clothes separate. Wash hands before breaks and at end of work.

Exposure limits:

The product may be detectable by odor below one tenth of the TLV (Threshold Limit Value).

TLV –TWA [mg/m³] : 590

TLV –TWA [ppm] : 200

TLV –STEL [mg/m³] : 737

TLV –STEL [ppm] : 250

9. Physical and chemical properties

Form: Liquid.

Color: transparent yellow.

Odor: ethereal.

Boiling point: 66°C

Flash point:-20 °C

Density: 0.92 -0.94 gr /cm³ (at 20°C)

Viscosity: 28,000CPS (at 23°C)

Solubility in water: Not miscible or difficult to mix.

10. Stability and reactivity

Hazardous polymerization: May occur in the presence of cationic initiators such as strong proton acids or selected Lewis acids.

Stability: Stable with an appropriate level of inhibitor, but reactive (unstable) without.

May form explosive peroxides.

Materials and conditions to avoid (incompatibility): It is explosive with potassium hydroxide, sodium hydroxide and sodium tetrahydroaluminate, since caustic alkalis deplete the inhibitors.

11. Toxicological information

Toxicity by ingestion LD50 (mg/kg): 3000 (rat)

Inhalation: Vapor concentrations above recommended exposure levels may be irritating to the eyes and the respiratory tract, may cause headaches and dizziness, could be anesthetic and may have other central nervous system effects.

Skin contact:

May produce skin irritation. Repeated or prolonged skin contact may cause dermatitis and defatting.

Eye contact:

Will cause eye discomfort, affecting the eyes.

Ingestion:

Small amount of liquid aspirated into the respiratory system during ingestion or from vomiting may cause bronchopneumonia or pulmonary edema.

12. Ecological information

Ecological effects information: Treated effluent may be biodegradable.

Persistence and degradability: If the compound is released to

atmosphere: the substance

Photo degrades.

13. Disposal considerations

Disposal: Incinerate liquid residues and solids used as spillage absorbents. (Dispose only

By approved contractors following regulations covering disposal of these materials).

14. Transport information

AIR (ICAO/IATA)

ADR/RID class: 3 Flammable liquids.

Class: 3

UN Number: 1133

Label: 3

Proper shipping name: Adhesive; containing flammable liquid.

Maritime transport IMDG:

Class: 3

UN Number: 1133

Label: 3

Proper shipping name: ADHESIVES

15. Regulatory information

Hazard symbol(s):

Highly flammable.

Irritant.

R Phrase(s):

R11- Highly flammable

R19- May form explosive peroxides.

R36/37 – Irritating to eyes and respiratory system.

R 20- Harmful by inhalation.

S Phrase(s):

S16 – Keep away from sources of ignition – No smoking.

S29 – Do not empty into drains.

S33 – Take precautionary measures against static discharges.

S 25- Avoid contact with eyes.

16. Other information

The information here in was gathered from the raw materials suppliers. It is the duty of the user to verify the data and use the product responsibly as per his requirements and the Producers instructions. Adhestick LTD or its employees will not be held responsible for any damage caused by the use of this information and/or the product.



MAPAL PLASTICS
AGRICULTURAL PRODUCTS DIVISION
MEVO HAMMA, 12934 ISRAEL

Tel: +972-4-6764554

Cell: +972-52-8695355
+972-52-3677299

rubzvi@mapalplastics.com
erick@mapalplastics.com
mapal@mapalplastics.com

web: <http://www.mapalagro.com>